

**Břitové destičky GEN2 T-A®**

Série 0 | Rozsah průměrů: 12,98 mm - 17,65 mm (0.511" - 0.695")

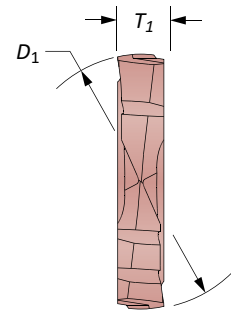
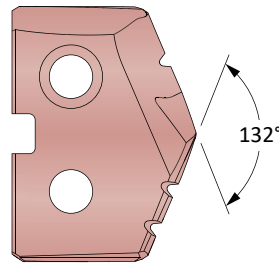

Destičky HSS – Super Cobalt • Karbidové destičky – K20 (C2) | K35 (C1)

Série	Destička				Kód destičky		
	D_1 mm	D_1 inch	Palců (zlomkem)	T_1 mm	Super Cobalt	K20 (C2)	K35 (C1)
0	13.00	0.5118	–	3.18	450H-13	4C20H-13	4C10H-13
	13.10	0.5156	33/64		450H-.515	4C20H-.515	4C10H-.515
	13.49	0.5313	17/32		450H-0017	4C20H-0017	4C10H-0017
	13.50	0.5315	–		450H-13.5	4C20H-13.5	4C10H-13.5
	13.89	0.5469	35/64		450H-.546	4C20H-.546	4C10H-.546
	14.00	0.5512	–		450H-14	4C20H-14	4C10H-14
	14.29	0.5625	9/16		450H-0018	4C20H-0018	4C10H-0018
	14.50	0.5709	–		450H-14.5	4C20H-14.5	4C10H-14.5
	14.68	0.5781	37/64		450H-.578	4C20H-.578	4C10H-.578
	15.00	0.5906	–		450H-15	4C20H-15	4C10H-15
0.5	15.08	0.5938	19/32	3.18	450H-0019	4C20H-0019	4C10H-0019
	15.48	0.6094	39/64		450H-.609	4C20H-.609	4C10H-.609
	15.50	0.6102	–		450H-15.5	4C20H-15.5	4C10H-15.5
	15.88	0.6250	5/8		450H-0020	4C20H-0020	4C10H-0020
	16.00	0.6299	–		450H-16	4C20H-16	4C10H-16
	16.27	0.6406	41/64		450H-.640	4C20H-.640	4C10H-.640
	16.50	0.6496	–		450H-16.5	4C20H-16.5	4C10H-16.5
	16.67	0.6563	21/32		450H-0021	4C20H-0021	4C10H-0021
	17.00	0.6693	–		450H-17	4C20H-17	4C10H-17
	17.07	0.6719	43/64		450H-.671	4C20H-.671	4C10H-.671
17.46	0.6875	11/16	450H-0022	4C20H-0022	4C10H-0022		
17.50	0.6890	–	450H-17.5	4C20H-17.5	4C10H-17.5		

POZNÁMKA: Destičky série 0.5 lze použít jak v držácích série 0, tak 0.5, ale destičky série 0 pouze v držácích série 0. Bližší informace na str. A30: 7

Destičky jsou dodávány po dvou kusech

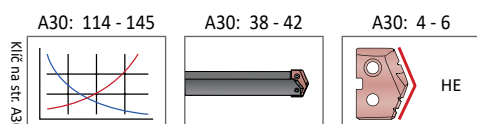

Položky s povlaky
neuvezenými výše jsou
dodávány jako nestandardní.



TiN = 131T-XXXX	TiAlN = 131A-XXXX
TiCN = 131N-XXXX	AM200® = 131H-XXXX

Břítové destičky T-A® Original

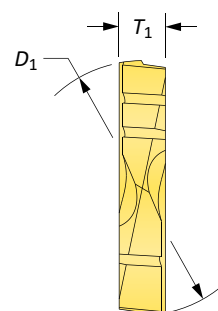
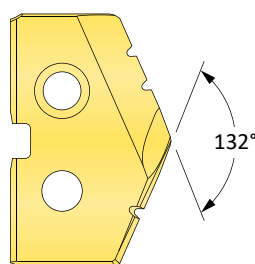
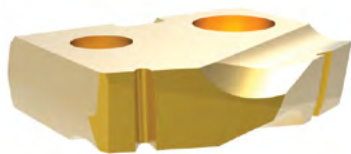
Série 0 | HSS | Rozsah průměrů: 12,98 mm - 17,65 mm (0.511" - 0.695")



Destičky HSS – Premium Cobalt

Série	Destička				Kód		
	D_1 mm	D_1 inch	Palců (zlomkem)	T_1 mm	 TiN	 TiAlN	 TiCN
0	13.00	0.5118	–	3.18	180T-13	180A-13	180N-13
	13.10	0.5156	33/64		180T-.515	180A-.515	180N-.515
	13.49	0.5313	17/32		180T-0017	180A-0017	180N-0017
	13.50	0.5315	–		180T-13.5	180A-13.5	180N-13.5
	13.89	0.5469	35/64		180T-.546	180A-.546	180N-.546
	14.00	0.5512	–		180T-14	180A-14	180N-14
	14.29	0.5625	9/16		180T-0018	180A-0018	180N-0018
	14.50	0.5709	–		180T-14.5	180A-14.5	180N-14.5
	14.68	0.5781	37/64		180T-.578	180A-.578	180N-.578
	15.00	0.5906	–		180T-15	180A-15	180N-15
15.08	0.5938	19/32	180T-0019	180A-0019	180N-0019		
0.5	15.48	0.6094	39/64	3.18	180T-.609	180A-.609	180N-.609
	15.50	0.6102	–		180T-15.5	180A-15.5	180N-15.5
	15.88	0.6250	5/8		180T-0020	180A-0020	180N-0020
	16.00	0.6299	–		180T-16	180A-16	180N-16
	16.27	0.6406	41/64		180T-.640	180A-.640	180N-.640
	16.50	0.6496	–		180T-16.5	180A-16.5	180N-16.5
	16.67	0.6563	21/32		180T-0021	180A-0021	180N-0021
	17.00	0.6693	–		180T-17	180A-17	180N-17
	17.07	0.6719	43/64		180T-.671	180A-.671	180N-.671
	17.46	0.6875	11/16		180T-0022	180A-0022	180N-0022
17.50	0.6890	–	180T-17.5	180A-17.5	180N-17.5		

POZNÁMKA: Destičky série 0.5 lze použít jak v držácích série 0, tak 0.5, ale destičky série 0 pouze v držácích série 0. Bližší informace na str. A30: 8

A30: 114 - 145

A30: 38 - 42

A30: 4 - 6

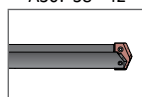
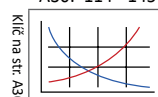

HI, HR, CR, TC, SK,
NP, IN, RN, CN, AN,
BR, CI, CP, NC, WC

Položky s povlaky
neuvezenými výše jsou
dodávány jako nestandardní.



Destičky jsou dodávány po dvou kusech

TiN = 131T-XXXX	TiAlN = 131A-XXXX
TiCN = 131N-XXXX	AM200® = 131H-XXXX

**Břítové destičky T-A® Original**

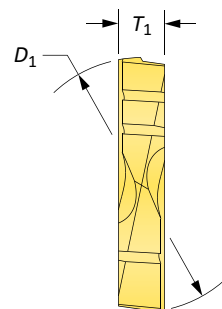
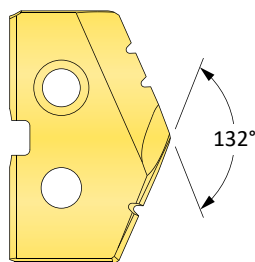
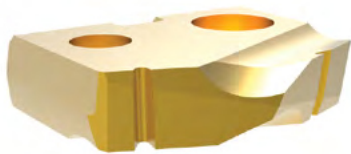
Série 0 | HSS | Rozsah průměrů: 12,98 mm - 17,65 mm (0.511" - 0.695")

**Destičky HSS – Super Cobalt**

Série	Destička			T ₁ mm	Kód		
	D ₁ mm	D ₁ inch	Palců (zlomkem)		 TiN	 TiAlN	 TiCN
0	13.00	0.5118	–	3.18	150T-13	150A-13	150N-13
	13.10	0.5156	33/64		150T-.515	150A-.515	150N-.515
	13.49	0.5313	17/32		150T-0017	150A-0017	150N-0017
	13.50	0.5315	–		150T-13.5	150A-13.5	150N-13.5
	13.89	0.5469	35/64		150T-.546	150A-.546	150N-.546
	14.00	0.5512	–		150T-14	150A-14	150N-14
	14.29	0.5625	9/16		150T-0018	150A-0018	150N-0018
	14.50	0.5709	–		150T-14.5	150A-14.5	150N-14.5
	14.68	0.5781	37/64		150T-.578	150A-.578	150N-.578
	15.00	0.5906	–		150T-15	150A-15	150N-15
0.5	15.08	0.5938	19/32	3.18	150T-0019	150A-0019	150N-0019
	15.48	0.6094	39/64		150T-.609	150A-.609	150N-.609
	15.50	0.6102	–		150T-15.5	150A-15.5	150N-15.5
	15.88	0.6250	5/8		150T-0020	150A-0020	150N-0020
	16.00	0.6299	–		150T-16	150A-16	150N-16
	16.27	0.6406	41/64		150T-.640	150A-.640	150N-.640
	16.50	0.6496	–		150T-16.5	150A-16.5	150N-16.5
	16.67	0.6563	21/32		150T-0021	150A-0021	150N-0021
	17.00	0.6693	–		150T-17	150A-17	150N-17
	17.07	0.6719	43/64		150T-.671	150A-.671	150N-.671
0.5	17.46	0.6875	11/16	3.18	150T-0022	150A-0022	150N-0022
	17.50	0.6890	–		150T-17.5	150A-17.5	150N-17.5

POZNÁMKA: Destičky série 0.5 lze použít jak v držácích série 0, tak 0.5, ale destičky série 0 pouze v držácích série 0. Bližší informace na str. A30: 7

A30: 114 - 145

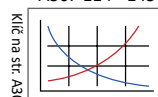

Klíč na str. A30: 1

A30: 38 - 42

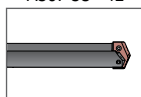

A30: 4 - 6

HI, HR, CR, TC, SK,
NP, IN, RN, CN, AN,
BR, CI, CP, NC, WCPoložky s povlaky
neuvedenými výše jsou
dodávány jako nestandardní.

Destičky jsou dodávány po dvou kusech

TiN = 131T-XXXX

TiAlN = 131A-XXXX

TiCN = 131N-XXXX

AM200® = 131H-XXXX

Břítové destičky T-A® Original

Série 0 | HSS | Rozsah průměrů: 12,98 mm - 17,65 mm (0.511" - 0.695")





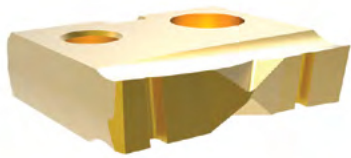
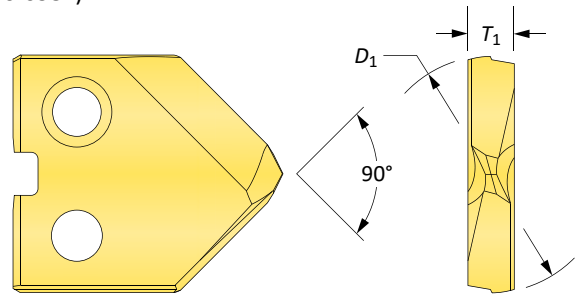

90° Spot & Chamfer

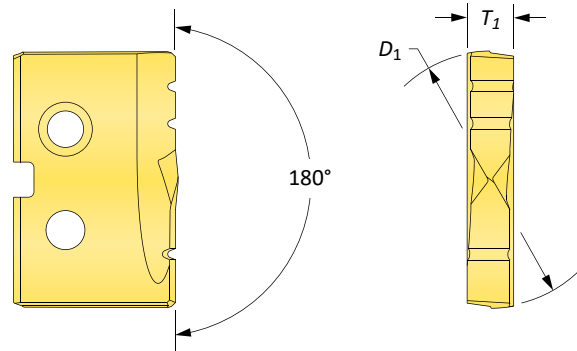

Rovné dno (FB)



Destičky HSS – Super Cobalt

Série	Destička			T ₁ mm	Kód 90° Spot & Chamfer			Kód Flat Bottom
	D ₁ mm	D ₁ inch	Palců (zlomkem)		 TiN	 TiAlN	 TiCN	 TiN
0	13.00	0.5118	–	3.18	150T-13-SP	150A-13-SP	150N-13-SP	150T-13-FB
	13.10	0.5156	33/64		150T-.515-SP	150A-.515-SP	150N-.515-SP	150T-.515-FB
	13.49	0.5313	17/32		150T-0017-SP	150A-0017-SP	150N-0017-SP	150T-0017-FB
	13.50	0.5315	–		150T-13.5-SP	150A-13.5-SP	150N-13.5-SP	150T-13.5-FB
	13.89	0.5469	35/64		150T-.546-SP	150A-.546-SP	150N-.546-SP	150T-.546-FB
	14.00	0.5512	–		150T-14-SP	150A-14-SP	150N-14-SP	150T-14-FB
	14.29	0.5625	9/16		150T-0018-SP	150A-0018-SP	150N-0018-SP	150T-0018-FB
	14.50	0.5709	–		150T-14.5-SP	150A-14.5-SP	150N-14.5-SP	150T-14.5-FB
	14.68	0.5781	37/64		150T-.578-SP	150A-.578-SP	150N-.578-SP	150T-.578-FB
	15.00	0.5906	–		150T-15-SP	150A-15-SP	150N-15-SP	150T-15-FB
0.5	15.08	0.5938	19/32	3.18	150T-0019-SP	150A-0019-SP	150N-0019-SP	150T-0019-FB
	15.48	0.6094	39/64		150T-.609-SP	150A-.609-SP	150N-.609-SP	150T-.609-FB
	15.50	0.6102	–		150T-15.5-SP	150A-15.5-SP	150N-15.5-SP	150T-15.5-FB
	15.88	0.6250	5/8		150T-0020-SP	150A-0020-SP	150N-0020-SP	150T-0020-FB
	16.00	0.6299	–		150T-16-SP	150A-16-SP	150N-16-SP	150T-16-FB
	16.27	0.6406	41/64		150T-.640-SP	150A-.640-SP	150N-.640-SP	150T-.640-FB
	16.50	0.6496	–		150T-16.5-SP	150A-16.5-SP	150N-16.5-SP	150T-16.5-FB
	16.67	0.6563	21/32		150T-0021-SP	150A-0021-SP	150N-0021-SP	150T-0021-FB
	17.00	0.6693	–		150T-17-SP	150A-17-SP	150N-17-SP	150T-17-FB
	17.07	0.6719	43/64		150T-.671-SP	150A-.671-SP	150N-.671-SP	150T-.671-FB
17.46	0.6875	11/16	150T-0022-SP	150A-0022-SP	150N-0022-SP	150T-0022-FB		
17.50	0.6890	–	150T-17.5-SP	150A-17.5-SP	150N-17.5-SP	150T-17.5-FB		

POZNÁMKA: Destičky série 0.5 lze použít jak v držácích série 0, tak 0.5, ale destičky série 0 pouze v držácích série 0. Bližší informace na str. A30: 7

A30: 114 - 145

A30: 38 - 42

A30: 4 - 6

A30: 4 - 6

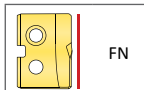
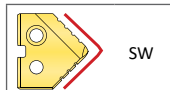
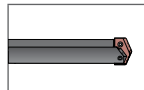
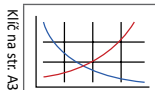

Položky s povlaky neuvedenými výše jsou dodávány jako nestandardní.

Destičky jsou dodávány po dvou kusech

TiN = 131T-XXXX	TiAlN = 131A-XXXX
TiCN = 131N-XXXX	AM200® = 131H-XXXX

Břitové destičky T-A® Original

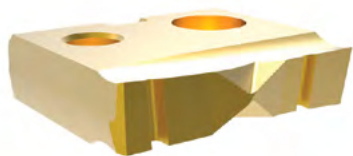
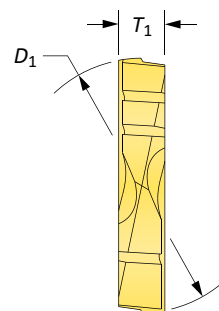
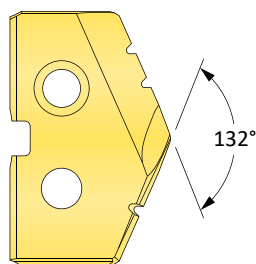

Série 0 | Karbidové | Rozsah průměrů: 12,98 mm - 17,65 mm (0.511" - 0.695")

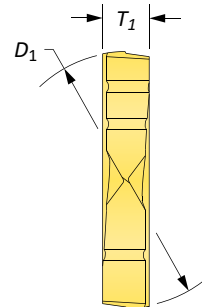
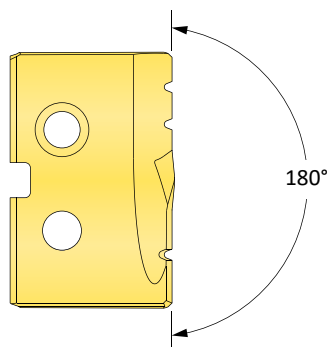

Rovné dno (FB)





Karbidové destičky – K20 (C2)

Série	Destička				Kód		Kód Flat Bottom
	D_1 mm	D_1 inch	Palců (zlomkem)	T_1 mm	 TiN	 TiAlN	 TiN
0	13.00	0.5118	–	3.18	1C20T-13	1C20A-13	1C20T-13-FB
	13.10	0.5156	33/64		1C20T-.515	1C20A-.515	1C20T-.515-FB
	13.49	0.5313	17/32		1C20T-0017	1C20A-0017	1C20T-0017-FB
	13.50	0.5315	–		1C20T-13.5	1C20A-13.5	1C20T-13.5-FB
	13.89	0.5469	35/64		1C20T-.546	1C20A-.546	1C20T-.546-FB
	14.00	0.5512	–		1C20T-14	1C20A-14	1C20T-14-FB
	14.29	0.5625	9/16		1C20T-0018	1C20A-0018	1C20T-0018-FB
	14.50	0.5709	–		1C20T-14.5	1C20A-14.5	1C20T-14.5-FB
	14.68	0.5781	37/64		1C20T-.578	1C20A-.578	1C20T-.578-FB
	15.00	0.5906	–		1C20T-15	1C20A-15	1C20T-15-FB
0.5	15.08	0.5938	19/32	3.18	1C20T-0019	1C20A-0019	1C20T-0019-FB
	15.48	0.6094	39/64		1C20T-.609	1C20A-.609	1C20T-.609-FB
	15.50	0.6102	–		1C20T-15.5	1C20A-15.5	1C20T-15.5-FB
	15.88	0.6250	5/8		1C20T-0020	1C20A-0020	1C20T-0020-FB
	16.00	0.6299	–		1C20T-16	1C20A-16	1C20T-16-FB
	16.27	0.6406	41/64		1C20T-.640	1C20A-.640	1C20T-.640-FB
	16.50	0.6496	–		1C20T-16.5	1C20A-16.5	1C20T-16.5-FB
	16.67	0.6563	21/32		1C20T-0021	1C20A-0021	1C20T-0021-FB
	17.00	0.6693	–		1C20T-17	1C20A-17	1C20T-17-FB
	17.07	0.6719	43/64		1C20T-.671	1C20A-.671	1C20T-.671-FB
	17.46	0.6875	11/16		1C20T-0022	1C20A-0022	1C20T-0022-FB
	17.50	0.6890	–		1C20T-17.5	1C20A-17.5	1C20T-17.5-FB

POZNÁMKA: Destičky série 0.5 lze použít jak v držácích série 0, tak 0.5, ale destičky série 0 pouze v držácích série 0. Bližší informace na str. A30: 7

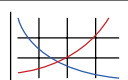
Destičky jsou dodávány po dvou kusech

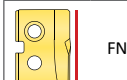
A30: 114 - 145 	A30: 38 - 42 	A30: 4 - 6  HI, HR, CR, TC, SK, NP, IN, RN, CN, AN, BR, CI, CP, NC, WC	A30: 4 - 6  FN
---	---	--	--

Položky s povlaky neuvedenými výše jsou dodávány jako nestandardní.

TiN = 131T-XXXX	TiAlN = 131A-XXXX
TiCN = 131N-XXXX	AM200® = 131H-XXXX





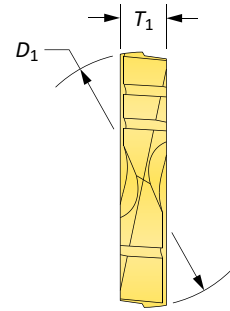
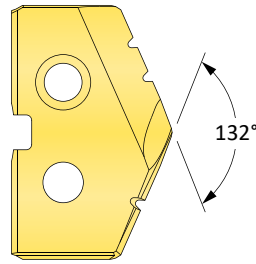
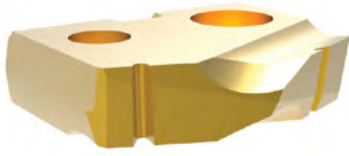

Břítové destičky T-A® Original

Série 0 | Karbidové | Rozsah průměrů: 12,98 mm - 17,65 mm (0.511" - 0.695")



Karbidové destičky - P35 (C5) | K10 (C3) | N2

Série	Destička			T_1	Kód C5		Kód C3	Kód N2
	D_1 mm	D_1 inch	Palců (zlomkem)		 TiN	 TiAlN	 TiAlN (Cast Iron)	 Diamond Film
0	13.00	0.5118	-	3.18	1C50T-13	1C50A-13	1C30A-13-CI	1N20D-13
	13.10	0.5156	33/64		1C50T-.515	1C50A-.515	1C30A-.515-CI	1N20D-.515
	13.49	0.5313	17/32		1C50T-0017	1C50A-0017	1C30A-0017-CI	1N20D-0017
	13.50	0.5315	-		1C50T-13.5	1C50A-13.5	1C30A-13.5-CI	1N20D-13.5
	13.89	0.5469	35/64		1C50T-.546	1C50A-.546	1C30A-.546-CI	1N20D-.546
	14.00	0.5512	-		1C50T-14	1C50A-14	1C30A-14-CI	1N20D-14
	14.29	0.5625	9/16		1C50T-0018	1C50A-0018	1C30A-0018-CI	1N20D-0018
	14.50	0.5709	-		1C50T-14.5	1C50A-14.5	1C30A-14.5-CI	1N20D-14.5
	14.68	0.5781	37/64		1C50T-.578	1C50A-.578	1C30A-.578-CI	1N20D-.578
	15.00	0.5906	-		1C50T-15	1C50A-15	1C30A-15-CI	1N20D-15
	15.08	0.5938	19/32		1C50T-0019	1C50A-0019	1C30A-0019-CI	1N20D-0019
0.5	15.48	0.6094	39/64	3.18	1C50T-.609	1C50A-.609	1C30A-.609-CI	1N20D-.609
	15.50	0.6102	-		1C50T-15.5	1C50A-15.5	1C30A-15.5-CI	1N20D-15.5
	15.88	0.6250	5/8		1C50T-0020	1C50A-0020	1C30A-0020-CI	1N20D-0020
	16.00	0.6299	-		1C50T-16	1C50A-16	1C30A-16-CI	1N20D-16
	16.27	0.6406	41/64		1C50T-.640	1C50A-.640	1C30A-.640-CI	1N20D-.640
	16.50	0.6496	-		1C50T-16.5	1C50A-16.5	1C30A-16.5-CI	1N20D-16.5
	16.67	0.6563	21/32		1C50T-0021	1C50A-0021	1C30A-0021-CI	1N20D-0021
	17.00	0.6693	-		1C50T-17	1C50A-17	1C30A-17-CI	1N20D-17
	17.07	0.6719	43/64		1C50T-.671	1C50A-.671	1C30A-.671-CI	1N20D-.671
	17.46	0.6875	11/16		1C50T-0022	1C50A-0022	1C30A-0022-CI	1N20D-0022
	17.50	0.6890	-		1C50T-17.5	1C50A-17.5	1C30A-17.5-CI	1N20D-17.5

POZNÁMKA: Destičky série 0.5 lze použít jak v držácích série 0, tak 0.5, ale destičky série 0 pouze v držácích série 0. Bližší informace na str. A30: 7

A30: 114 - 145

A30: 38 - 42

A30: 4 - 6

Klíč na str. A30: 1

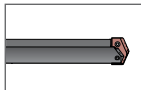
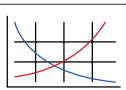

HI, HR, CR, TC, SK,
NP, IN, RN, CN, AN,
BR, CI, CP, NC, WC

Položky s povlaky
neuvezenými výše jsou
dodávány jako nestandardní.



Destičky jsou dodávány po dvou kusech

TiN = 131T-XXXX	TiAlN = 131A-XXXX
TiCN = 131N-XXXX	AM200® = 131H-XXXX