

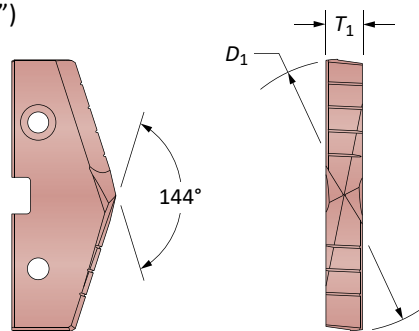

Břitové destičky GEN2 T-A®

Série 5 | HSS | Rozsah průměrů: 62,38 mm - 76,20 mm (2.456" - 3.000")

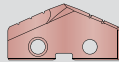

Destičky HSS - Super Cobalt | HSS

Destička			T ₁ mm	Kód Super Cobalt	Kód destičky HSS
D ₁ mm	D ₁ inch	Palců (zlomkem)		 AM200®	 TiN
63.50	2.5000	2-1/2	11.11	455H-0216	435T-0216
64.00	2.5197	-		455H-64	435T-64
64.29	2.5313	2-17/32		455H-0217	435T-0217
65.09	2.5625	2-9/16		455H-0218	435T-0218
65.88	2.5938	2-19/32		455H-0219	435T-0219
66.00	2.5984	-		455H-66	435T-66
66.68	2.6250	2-5/8		455H-0220	435T-0220
67.47	2.6563	2-21/32		455H-0221	435T-0221
68.00	2.6772	-		455H-68	435T-68
68.26	2.6875	2-11/16		455H-0222	435T-0222
69.05	2.7188	2-23/32		455H-0223	435T-0223
69.85	2.7500	2-3/4		455H-0224	435T-0224
70.00	2.7559	-		455H-70	435T-70
70.64	2.7813	2-25/32		455H-0225	435T-0225
71.44	2.8125	2-13/16		455H-0226	435T-0226
72.00	2.8346	-		455H-72	435T-72
72.23	2.8438	2-27/32		455H-0227	435T-0227
73.03	2.8750	2-7/8		455H-0228	435T-0228
73.82	2.9063	2-29/32		455H-0229	435T-0229
74.00	2.9134	-		455H-74	435T-74
74.41	2.9375	2-15/16	455H-0230	435T-0230	
75.61	2.9688	2-31/32	455H-0231	435T-0231	
76.00	2.9921	-	455H-76	435T-76	
76.20	3.0000	3	455H-0300	435T-0300	

F ZÁVITOVÁNÍ

X OSTATNÍ

Destičky se dodávají po 1 ks

Položky s povlaky neuvedenými výše jsou dodávány jako nestandardní.

TiN = 131T-XXXX	TiAlN = 131A-XXXX
TiCN = 131N-XXXX	AM200® = 131H-XXXX



A30: 114 - 145

A30: 98 - 100

A30: 4 - 6

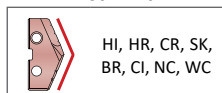
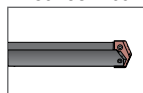
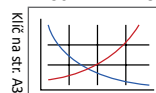

Břitové destičky T-A® Original

Série 5 | HSS | Rozsah průměrů: 62,38 mm - 76,20 mm (2.456" - 3.000")

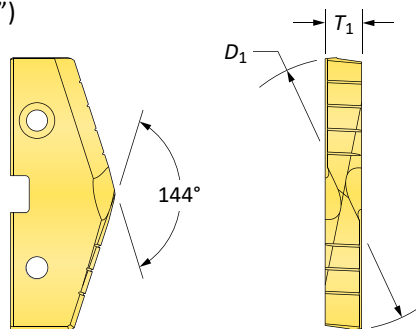

Destičky HSS - Super Cobalt | HSS

Destička			T ₁ mm	Kód Super Cobalt*	Kód destičky HSS
D ₁ mm	D ₁ inch	Palců (zlomkem)		TiN	TiN
63.50	2.5000	2-1/2	11.11	155T-0216	135T-0216
64.00	2.5197	-		155T-64	135T-64
64.29	2.5313	2-17/32		155T-0217	135T-0217
65.09	2.5625	2-9/16		155T-0218	135T-0218
65.88	2.5938	2-19/32		155T-0219	135T-0219
66.00	2.5984	-		155T-66	135T-66
66.68	2.6250	2-5/8		155T-0220	135T-0220
67.47	2.6563	2-21/32		155T-0221	135T-0221
68.00	2.6772	-		155T-68	135T-68
68.26	2.6875	2-11/16		155T-0222	135T-0222
69.05	2.7188	2-23/32		155T-0223	135T-0223
69.85	2.7500	2-3/4		155T-0224	135T-0224
70.00	2.7559	-		155T-70	135T-70
70.64	2.7813	2-25/32		155T-0225	135T-0225
71.44	2.8125	2-13/16		155T-0226	135T-0226
72.00	2.8346	-		155T-72	135T-72
72.23	2.8438	2-27/32		155T-0227	135T-0227
73.03	2.8750	2-7/8		155T-0228	135T-0228
73.82	2.9063	2-29/32		155T-0229	135T-0229
74.00	2.9134	-		155T-74	135T-74
74.41	2.9375	2-15/16	155T-0230	135T-0230	
75.61	2.9688	2-31/32	155T-0231	135T-0231	
76.00	2.9921	-	155T-76	135T-76	
76.20	3.0000	3	155T-0300	135T-0300	

*Dostupné jako standardní neskladové položky

A30: 114 - 145

Klíč na str. A30: 1

A30: 98 - 100

A30: 4 - 6

HI, HR, CR, SK,
BR, CI, NC, WC

Položky s povlaky neuvedenými výše jsou dodávány jako nestandardní.



Destičky se dodávají po 1 ks

TiN = 131T-XXXX	TiAlN = 131A-XXXX
TiCN = 131N-XXXX	AM200® = 131H-XXXX

A

VRTÁNÍ

B

VYVRTÁVÁNÍ

C

VYSTRUŽOVÁNÍ

D

VÁLEČKOVÁNÍ

F

ZÁVITOVÁNÍ

X

OSTATNÍ

Břitové destičky GEN2 T-A®

Série 6 | HSS | Rozsah průměrů: 76,22 mm - 89,08 mm (3.001" - 3.507")

(Pro použití s držáky série 5)

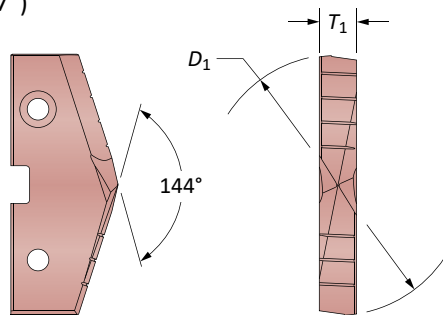

Destičky HSS - Super Cobalt | HSS

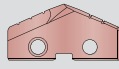
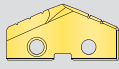
Destička			T ₁ mm	Kód Super Cobalt	Kód destičky HSS
D ₁ mm	D ₁ inch	Palců (zlomkem)		 AM200®	 TiN
76.99	3.0313	3-1/32	11.11	456H-0301	436T-0301
77.79	3.0625	3-1/16		456H-0302	436T-0302
78.00	3.0709	-		456H-78	436T-78
78.58	3.0938	3-3/32		456H-0303	436T-0303
79.38	3.1250	3-1/8		456H-0304	436T-0304
80.00	3.1496	-		456H-80	436T-80
80.17	3.1563	3-5/32		456H-0305	436T-0305
80.96	3.1875	3-3/16		456H-0306	436T-0306
81.76	3.2188	3-7/32		456H-0307	436T-0307
82.00	3.2283	-		456H-82	436T-82
82.55	3.2500	3-1/4		456H-0308	436T-0308
83.34	3.2813	3-9/32		456H-0309	436T-0309
84.00	3.3071	-		456H-84	436T-84
84.14	3.3125	3-5/16		456H-0310	436T-0310
84.93	3.3438	3-11/32		456H-0311	436T-0311
85.73	3.3750	3-3/8		456H-0312	436T-0312
86.00	3.3858	-		456H-86	436T-86
86.52	3.4063	3-13/32		456H-0313	436T-0313
87.31	3.4375	3-7/16		456H-0314	436T-0314
88.00	3.4646	-		456H-88	436T-88
88.11	3.4688	3-15/32	456H-0315	436T-0315	
88.90	3.5000	3-1/2	456H-0316	436T-0316	

Destičky se dodávají po 1 ks

Položky s povlaky neuvedenými výše jsou dodávány jako nestandardní.



TiN = 131T-XXXX	TiAlN = 131A-XXXX
TiCN = 131N-XXXX	AM200® = 131H-XXXX

A30: 114 - 145

A30: 98 - 100

A30: 4 - 6

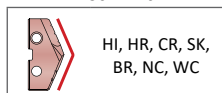
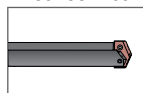
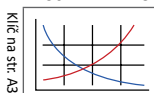

HI, HR, CR, SK,
BR, NC, WC

Břítové destičky T-A® Original

Série 6 | HSS | Rozsah průměrů: 76.22 mm - 89.08 mm (3.001" - 3.507")

(Pro použití s držáky série 5)

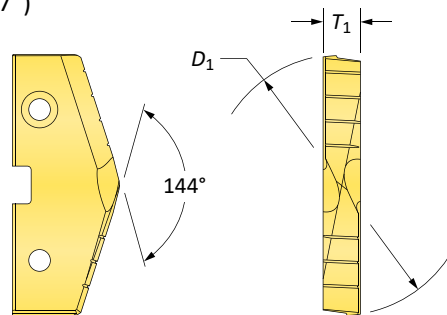

Destičky HSS - Super Cobalt | HSS

Destička			T ₁ mm	Kód Super Cobalt*	Kód destičky HSS
D ₁ mm	D ₁ inch	Palců (zlomkem)		TiN	TiN
76.99	3.0313	3-1/32	11.11	156T-0301	136T-0301
77.79	3.0625	3-1/16		156T-0302	136T-0302
78.00	3.0709	-		156T-78	136T-78
78.58	3.0938	3-3/32		156T-0303	136T-0303
79.38	3.1250	3-1/8		156T-0304	136T-0304
80.00	3.1496	-		156T-80	136T-80
80.17	3.1563	3-5/32		156T-0305	136T-0305
80.96	3.1875	3-3/16		156T-0306	136T-0306
81.76	3.2188	3-7/32		156T-0307	136T-0307
82.00	3.2283	-		156T-82	136T-82
82.55	3.2500	3-1/4		156T-0308	136T-0308
83.34	3.2813	3-9/32		156T-0309	136T-0309
84.00	3.3071	-		156T-84	136T-84
84.14	3.3125	3-5/16		156T-0310	136T-0310
84.93	3.3438	3-11/32		156T-0311	136T-0311
85.73	3.3750	3-3/8		156T-0312	136T-0312
86.00	3.3858	-		156T-86	136T-86
86.52	3.4063	3-13/32		156T-0313	136T-0313
87.31	3.4375	3-7/16		156T-0314	136T-0314
88.00	3.4646	-		156T-88	136T-88
88.11	3.4688	3-15/32	156T-0315	136T-0315	
88.90	3.5000	3-1/2	156T-0316	136T-0316	

*Dostupné jako standardní neskladové položky

A30: 114 - 145 A30: 98 - 100 A30: 4 - 6

HI, HR, CR, SK, BR, NC, WC

Položky s povlaky neuvedenými výše jsou dodávány jako nestandardní.

Destičky se dodávají po 1 ks

TiN = 131T-XXXX	TiAlN = 131A-XXXX
TiCN = 131N-XXXX	AM200® = 131H-XXXX