

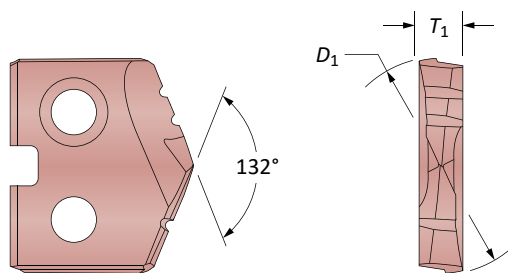



Břitové destičky GEN2 T-A®

Série Z | Rozsah průměrů: 11,10 mm - 12,95 mm (0.437" - 0.510")



Destičky HSS – Super Cobalt • Karbidové destičky – K20 (C2) | K35 (C1)

Destička			T_1 mm	Kód destičky HSS			Kód karbidové destičky		
D_1 mm	D_1 inch	Palců (zlomkem)		 Super Cobalt	 K20 (C2)	 K35 (C1)			
11.11	0.4375	7/16	2.38	45ZH-0014	4C2ZH-0014	4C1ZH-0014			
11.46	0.4510	–		45ZH-.451	4C2ZH-.451	4C1ZH-.451			
11.50	0.4528	–		45ZH-11.5	4C2ZH-11.5	4C1ZH-11.5			
11.51	0.4531	29/64		45ZH-.453	4C2ZH-.453	4C1ZH-.453			
11.91	0.4688	15/32		45ZH-0015	4C2ZH-0015	4C1ZH-0015			
12.00	0.4724	–		45ZH-12	4C2ZH-12	4C1ZH-12			
12.30	0.4844	31/64		45ZH-.484	4C2ZH-.484	4C1ZH-.484			
12.50	0.4921	–		45ZH-12.5	4C2ZH-12.5	4C1ZH-12.5			
12.70	0.5000	1/2		45ZH-0016	4C2ZH-0016	4C1ZH-0016			
12.85	0.5060	–		45ZH-.506	4C2ZH-.506	4C1ZH-.506			
12.95	0.5100	–		45ZH-.510	4C2ZH-.510	4C1ZH-.510			

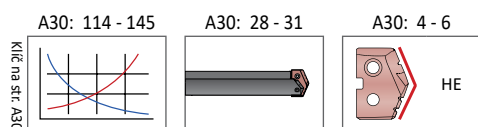

Položky s povlaky neuvedenými výše jsou dodávány jako nestandardní. →

Destičky jsou dodávány po dvou kusech



TiN = 131T-XXXX	TiAlN = 131A-XXXX
TiCN = 131N-XXXX	AM200® = 131H-XXXX

Břítové destičky T-A® Original

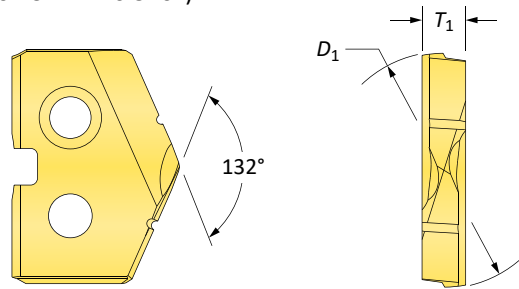
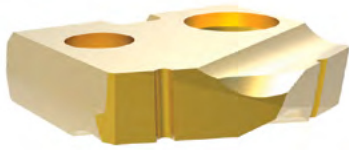
Série Z | HSS | Rozsah průměrů: 11,10 mm - 12,95 mm (0.437" - 0.510")



Destičky HSS – Premium Cobalt

Destička				Kód		
D_1 mm	D_1 inch	Palců (zlomkem)	T_1 mm	 TiN	 TiAlN	 TiCN
11.11	0.4375	7/16	2.38	18ZT-0014	18ZA-0014	18ZN-0014
11.46	0.4510	–		18ZT-.451	18ZA-.451	18ZN-.451
11.50	0.4528	–		18ZT-11.5	18ZA-11.5	18ZN-11.5
11.51	0.4531	29/64		18ZT-.453	18ZA-.453	18ZN-.453
11.91	0.4688	15/32		18ZT-0015	18ZA-0015	18ZN-0015
12.00	0.4724	–		18ZT-12	18ZA-12	18ZN-12
12.30	0.4844	31/64		18ZT-.484	18ZA-.484	18ZN-.484
12.50	0.4921	–		18ZT-12.5	18ZA-12.5	18ZN-12.5
12.70	0.5000	1/2		18ZT-0016	18ZA-0016	18ZN-0016
12.85	0.5060	–		18ZT-.506	18ZA-.506	18ZN-.506
12.95	0.5100	–		18ZT-.510	18ZA-.510	18ZN-.510

A30: 114 - 145

A30: 28 - 31

A30: 4 - 6

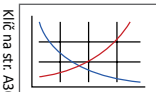

HI, HR, CR, TC, SK, NP, IN, RN, CN, AN, BR, CI, CP, NC, WC

Položky s povlaky neuvedenými výše jsou dodávány jako nestandardní.



Destičky jsou dodávány po dvou kusech

TiN = 131T-XXXX	TiAlN = 131A-XXXX
TiCN = 131N-XXXX	AM200® = 131H-XXXX



Klíč na str. A30: 1

Břítové destičky T-A® Original

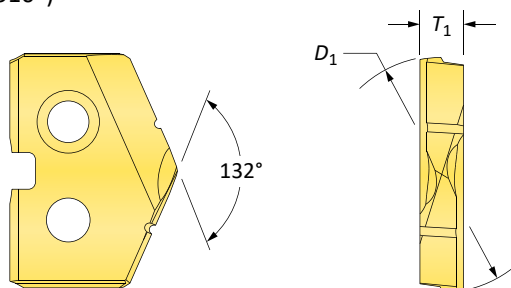
Série Z | HSS | Rozsah průměrů: 11,10 mm - 12,95 mm (0.437" - 0.510")



Destičky HSS – Super Cobalt

Destička				Kód		
D_1 mm	D_1 inch	Palců (zlomkem)	T_1 mm	 TiN	 TiAlN	 TiCN
11.11	0.4375	7/16	2.38	15ZT-0014	15ZA-0014	15ZN-0014
11.46	0.4510	-		15ZT-.451	15ZA-.451	15ZN-.451
11.50	0.4528	-		15ZT-11.5	15ZA-11.5	15ZN-11.5
11.51	0.4531	29/64		15ZT-.453	15ZA-.453	15ZN-.453
11.91	0.4688	15/32		15ZT-0015	15ZA-0015	15ZN-0015
12.00	0.4724	-		15ZT-12	15ZA-12	15ZN-12
12.30	0.4844	31/64		15ZT-.484	15ZA-.484	15ZN-.484
12.50	0.4921	-		15ZT-12.5	15ZA-12.5	15ZN-12.5
12.70	0.5000	1/2		15ZT-0016	15ZA-0016	15ZN-0016
12.85	0.5060	-		15ZT-.506	15ZA-.506	15ZN-.506
12.95	0.5100	-		15ZT-.510	15ZA-.510	15ZN-.510

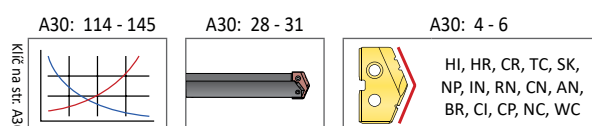

Položky s povlaky neuvedenými výše jsou dodávány jako nestandardní.



Destičky jsou dodávány po dvou kusech

TiN = 131T-XXXX	TiAlN = 131A-XXXX
TiCN = 131N-XXXX	AM200® = 131H-XXXX

Břítové destičky T-A® Original

Série Z | HSS | Rozsah průměrů: 11,10 mm - 12,95 mm (0.437" - 0.510")

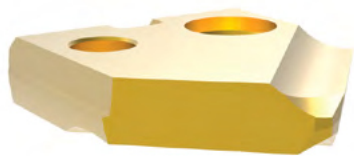

90° Spot & Chamfer

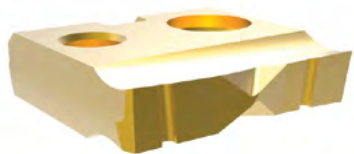
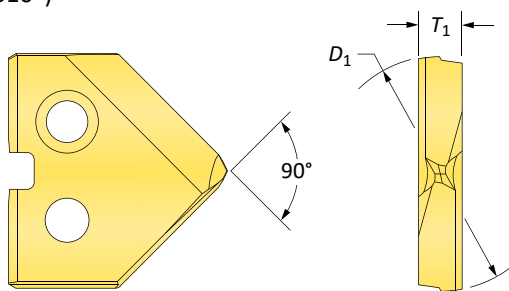

Rovné dno (FB)

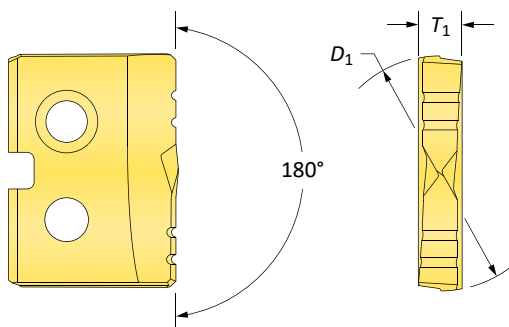

Destičky HSS – Super Cobalt

Destička				Kód 90° Spot & Chamfer			Kód Flat Bottom
D ₁ mm	D ₁ inch	Palců (zlomkem)	T ₁ mm				
				TiN	TiAlN	TiCN	TiN
11.11	0.4375	7/16	2.38	15ZT-0014-SP	15ZA-0014-SP	15ZN-0014-SP	15ZT-0014-FB
11.46	0.4510	-		15ZT-.451-SP	15ZA-.451-SP	15ZN-.451-SP	15ZT-.451-FB
11.50	0.4528	-		15ZT-11.5-SP	15ZA-11.5-SP	15ZN-11.5-SP	15ZT-11.5-FB
11.51	0.4531	29/64		15ZT-.453-SP	15ZA-.453-SP	15ZN-.453-SP	15ZT-.453-FB
11.91	0.4688	15/32		15ZT-0015-SP	15ZA-0015-SP	15ZN-0015-SP	15ZT-0015-FB
12.00	0.4724	-		15ZT-12-SP	15ZA-12-SP	15ZN-12-SP	15ZT-12-FB
12.30	0.4844	31/64		15ZT-.484-SP	15ZA-.484-SP	15ZN-.484-SP	15ZT-.484-FB
12.50	0.4921	-		15ZT-12.5-SP	15ZA-12.5-SP	15ZN-12.5-SP	15ZT-12.5-FB
12.70	0.5000	1/2		15ZT-0016-SP	15ZA-0016-SP	15ZN-0016-SP	15ZT-0016-FB
12.85	0.5060	-		15ZT-.506-SP	15ZA-.506-SP	15ZN-.506-SP	15ZT-.506-FB
12.95	0.5100	-		15ZT-.510-SP	15ZA-.510-SP	15ZN-.510-SP	15ZT-.510-FB

A30: 114 - 145

A30: 28 - 31

A30: 4 - 6

A30: 4 - 6

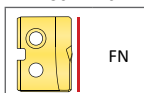
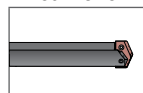
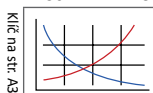

Položky s povlaky neuvedenými výše jsou dodávány jako nestandardní.



Destičky jsou dodávány po dvou kusech

TiN = 131T-XXXX	TiAlN = 131A-XXXX
TiCN = 131N-XXXX	AM200® = 131H-XXXX

Břítové destičky T-A® Original

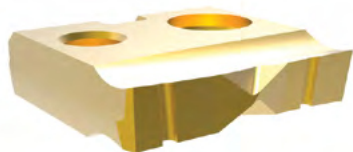
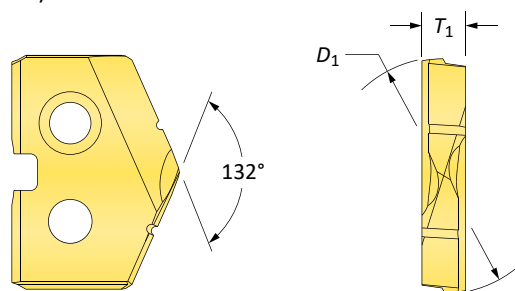

Série Z | Karbidové | Rozsah průměrů: 11,10 mm - 12,95 mm (0.437" - 0.510")

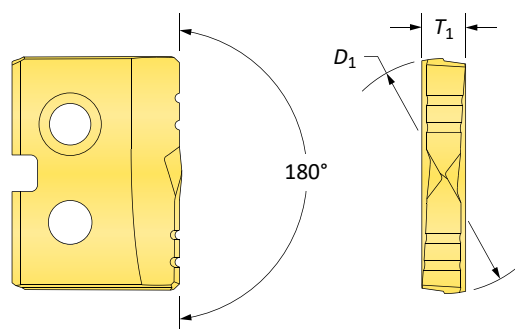

Rovné dno (FB)



Karbidové destičky – K20 (C2)

Destička				Kód		Kód Flat Bottom
D ₁ mm	D ₁ inch	Palců (zlomkem)	T ₁ mm			
				TiN	TiAlN	TiN
11.11	0.4375	7/16	2.38	1C2ZT-0014	1C2ZA-0014	1C2ZT-0014-FB
11.46	0.4510	–		1C2ZT-.451	1C2ZA-.451	1C2ZT-.451-FB
11.50	0.4528	–		1C2ZT-11.5	1C2ZA-11.5	1C2ZT-11.5-FB
11.51	0.4531	29/64		1C2ZT-.453	1C2ZA-.453	1C2ZT-.453-FB
11.91	0.4688	15/32		1C2ZT-0015	1C2ZA-0015	1C2ZT-0015-FB
12.00	0.4724	–		1C2ZT-12	1C2ZA-12	1C2ZT-12-FB
12.30	0.4844	31/64		1C2ZT-.484	1C2ZA-.484	1C2ZT-.484-FB
12.50	0.4921	–		1C2ZT-12.5	1C2ZA-12.5	1C2ZT-12.5-FB
12.70	0.5000	1/2		1C2ZT-0016	1C2ZA-0016	1C2ZT-0016-FB
12.85	0.5060	–		1C2ZT-.506	1C2ZA-.506	1C2ZT-.506-FB
12.95	0.5100	–		1C2ZT-.510	1C2ZA-.510	1C2ZT-.510-FB

Klíč na str. A30: 1

A30: 114 - 145

A30: 28 - 31

A30: 4 - 6

HI, HR, CR, TC, SK,
NP, IN, RN, CN, AN,
BR, CI, CP, NC, WC

A30: 4 - 6

FN

Položky s povlaky neuvedenými výše jsou dodávány jako nestandardní.

Destičky jsou dodávány po dvou kusech

TiN = 131T-XXXX	TiAlN = 131A-XXXX
TiCN = 131N-XXXX	AM200® = 131H-XXXX







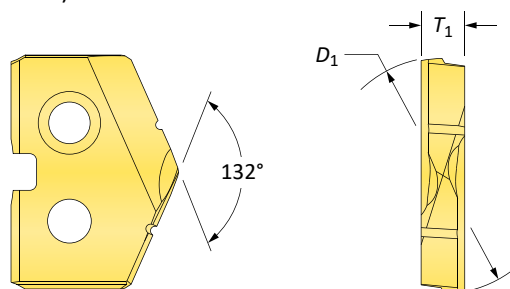
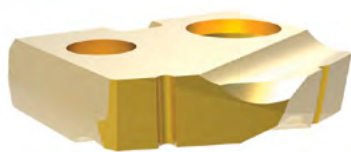



Břítové destičky T-A® Original

Série Z | Karbidové | Rozsah průměrů: 11,10 mm - 12,95 mm (0.437" - 0.510")

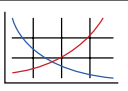

Karbidové destičky - P35 (C5) | K10 (C3) | N2

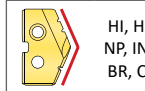
Destička				Kód C5		Kód C3	Kód N2
D_1 mm	D_1 inch	Palců (zlomkem)	T_1 mm	 TiN	 TiAlN	 TiAlN (Litina)	 Diamantový povlak
11.11	0.4375	7/16	2.38	1C5ZT-0014	1C5ZA-0014	1C3ZA-0014-CI	1N2ZD-0014
11.46	0.4510	-		1C5ZT-.451	1C5ZA-.451	1C3ZA-.451-CI	1N2ZD-.451
11.50	0.4528	-		1C5ZT-11.5	1C5ZA-11.5	1C3ZA-11.5-CI	1N2ZD-11.5
11.51	0.4531	29/64		1C5ZT-.453	1C5ZA-.453	1C3ZA-.453-CI	1N2ZD-.453
11.91	0.4688	15/32		1C5ZT-0015	1C5ZA-0015	1C3ZA-0015-CI	1N2ZD-0015
12.00	0.4724	-		1C5ZT-12	1C5ZA-12	1C3ZA-12-CI	1N2ZD-12
12.30	0.4844	31/64		1C5ZT-.484	1C5ZA-.484	1C3ZA-.484-CI	1N2ZD-.484
12.50	0.4921	-		1C5ZT-12.5	1C5ZA-12.5	1C3ZA-12.5-CI	1N2ZD-12.5
12.70	0.5000	1/2		1C5ZT-0016	1C5ZA-0016	1C3ZA-0016-CI	1N2ZD-0016
12.85	0.5060	-		1C5ZT-.506	1C5ZA-.506	1C3ZA-.506-CI	1N2ZD-.506
12.95	0.5100	-		1C5ZT-.510	1C5ZA-.510	1C3ZA-.510-CI	1N2ZD-.510

A30: 114 - 145   A30: 28 - 31  A30: 4 - 6  HI, HR, CR, TC, SK, NP, IN, RN, CN, AN, BR, CI, CP, NC, WC

Položky s povlaky neuvedenými výše jsou dodávány jako nestandardní.

Destičky jsou dodávány po dvou kusech

TiN = 131T-XXXX	TiAlN = 131A-XXXX
TiCN = 131N-XXXX	AM200® = 131H-XXXX