

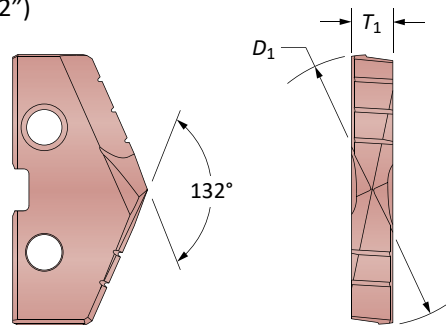

Břítové destičky GEN2 T-A®

Série 3 | HSS | Rozsah průměrů: 34,36 mm - 47,80 mm (1.353" - 1.882")

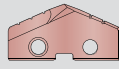
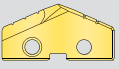

Destičky HSS – Premium Cobalt

| Destička | | | T ₁ mm | Kód | |
|-------------------|---------------------|-----------------|-------------------|--|---|
| D ₁ mm | D ₁ inch | Palců (zlomkem) | |  AM200® |  TiN |
| 35.72 | 1.4063 | 1-13/32 | 6.35 | 483H-0113 | 483T-0113 |
| 36.00 | 1.4173 | - | | 483H-36 | 483T-36 |
| 36.51 | 1.4375 | 1-7/16 | | 483H-0114 | 483T-0114 |
| 37.00 | 1.4567 | - | | 483H-37 | 483T-37 |
| 37.31 | 1.4688 | 1-15/32 | | 483H-0115 | 483T-0115 |
| 38.00 | 1.4961 | - | | 483H-38 | 483T-38 |
| 38.10 | 1.5000 | 1-1/2 | | 483H-0116 | 483T-0116 |
| 38.89 | 1.5313 | 1-17/32 | | 483H-0117 | 483T-0117 |
| 39.00 | 1.5354 | - | | 483H-39 | 483T-39 |
| 39.29 | 1.5470 | - | | 483H-1.547 | 483T-1.547 |
| 39.69 | 1.5625 | 1-9/16 | | 483H-0118 | 483T-0118 |
| 40.00 | 1.5748 | - | | 483H-40 | 483T-40 |
| 40.48 | 1.5938 | 1-19/32 | | 483H-0119 | 483T-0119 |
| 41.00 | 1.6142 | - | | 483H-41 | 483T-41 |
| 41.28 | 1.6250 | 1-5/8 | | 483H-0120 | 483T-0120 |
| 42.00 | 1.6535 | - | | 483H-42 | 483T-42 |
| 42.07 | 1.6563 | 1-21/32 | | 483H-0121 | 483T-0121 |
| 42.86 | 1.6875 | 1-11/16 | | 483H-0122 | 483T-0122 |
| 43.00 | 1.6929 | - | | 483H-43 | 483T-43 |
| 43.66 | 1.7188 | 1-23/32 | | 483H-0123 | 483T-0123 |
| 44.00 | 1.7323 | - | | 483H-44 | 483T-44 |
| 44.45 | 1.7500 | 1-3/4 | | 483H-0124 | 483T-0124 |
| 45.00 | 1.7717 | - | | 483H-45 | 483T-45 |
| 45.24 | 1.7813 | 1-25/32 | | 483H-0125 | 483T-0125 |
| 45.50 | 1.7913 | - | | 483H-45.5 | 483T-45.5 |
| 45.64 | 1.7970 | - | | 483H-1.797 | 483T-1.797 |
| 46.00 | 1.8110 | - | | 483H-46 | 483T-46 |
| 46.04 | 1.8125 | 1-13/16 | | 483H-0126 | 483T-0126 |
| 46.83 | 1.8438 | 1-27/32 | 483H-0127 | 483T-0127 | |
| 47.00 | 1.8504 | - | 483H-47 | 483T-47 | |
| 47.63 | 1.8750 | 1-7/8 | 483H-0128 | 483T-0128 | |

Destičky se dodávají po 1 ks

A30: 114 - 145

A30: 82 - 85

A30: 4 - 6

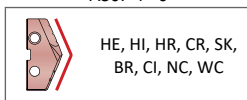
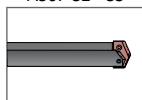
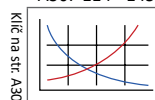

Položky s povlaky neuvedenými výše jsou dodávány jako nestandardní.



| | |
|------------------|--------------------|
| TiN = 131T-XXXX | TiAlN = 131A-XXXX |
| TiCN = 131N-XXXX | AM200® = 131H-XXXX |

Břitové destičky GEN2 T-A®

Série 3 | HSS | Rozsah průměrů: 34,36 mm - 47,80 mm (1.353" - 1.882")

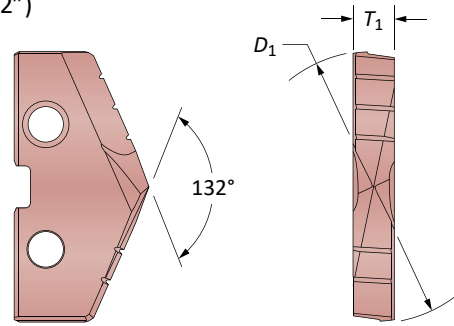

Destičky HSS – Super Cobalt

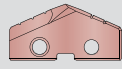
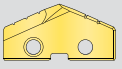
| Destička | | | T ₁ mm | Kód | |
|-------------------|---------------------|-----------------|-------------------|--|---|
| D ₁ mm | D ₁ inch | Palců (zlomkem) | |  AM200® |  TiN |
| 35.72 | 1.4063 | 1-13/32 | 6.35 | 453H-0113 | 453T-0113 |
| 36.00 | 1.4173 | - | | 453H-36 | 453T-36 |
| 36.51 | 1.4375 | 1-7/16 | | 453H-0114 | 453T-0114 |
| 37.00 | 1.4567 | - | | 453H-37 | 453T-37 |
| 37.31 | 1.4688 | 1-15/32 | | 453H-0115 | 453T-0115 |
| 38.00 | 1.4961 | - | | 453H-38 | 453T-38 |
| 38.10 | 1.5000 | 1-1/2 | | 453H-0116 | 453T-0116 |
| 38.89 | 1.5313 | 1-17/32 | | 453H-0117 | 453T-0117 |
| 39.00 | 1.5354 | - | | 453H-39 | 453T-39 |
| 39.29 | 1.5470 | - | | 453H-1.547 | 453T-1.547 |
| 39.69 | 1.5625 | 1-9/16 | | 453H-0118 | 453T-0118 |
| 40.00 | 1.5748 | - | | 453H-40 | 453T-40 |
| 40.48 | 1.5938 | 1-19/32 | | 453H-0119 | 453T-0119 |
| 41.00 | 1.6142 | - | | 453H-41 | 453T-41 |
| 41.28 | 1.6250 | 1-5/8 | | 453H-0120 | 453T-0120 |
| 42.00 | 1.6535 | - | | 453H-42 | 453T-42 |
| 42.07 | 1.6563 | 1-21/32 | | 453H-0121 | 453T-0121 |
| 42.86 | 1.6875 | 1-11/16 | | 453H-0122 | 453T-0122 |
| 43.00 | 1.6929 | - | | 453H-43 | 453T-43 |
| 43.66 | 1.7188 | 1-23/32 | | 453H-0123 | 453T-0123 |
| 44.00 | 1.7323 | - | | 453H-44 | 453T-44 |
| 44.45 | 1.7500 | 1-3/4 | | 453H-0124 | 453T-0124 |
| 45.00 | 1.7717 | - | | 453H-45 | 453T-45 |
| 45.24 | 1.7813 | 1-25/32 | | 453H-0125 | 453T-0125 |
| 45.50 | 1.7913 | - | | 453H-45.5 | 453T-45.5 |
| 45.64 | 1.7970 | - | | 453H-1.797 | 453T-1.797 |
| 46.00 | 1.8110 | - | | 453H-46 | 453T-46 |
| 46.04 | 1.8125 | 1-13/16 | | 453H-0126 | 453T-0126 |
| 46.83 | 1.8438 | 1-27/32 | 453H-0127 | 453T-0127 | |
| 47.00 | 1.8504 | - | 453H-47 | 453T-47 | |
| 47.63 | 1.8750 | 1-7/8 | 453H-0128 | 453T-0128 | |

Destičky se dodávají po 1 ks

Položky s povlaky neuvedenými výše jsou dodávány jako nestandardní.

| | |
|------------------|--------------------|
| TiN = 131T-XXXX | TiAlN = 131A-XXXX |
| TiCN = 131N-XXXX | AM200® = 131H-XXXX |



A30: 114 - 145

A30: 82 - 85

A30: 4 - 6

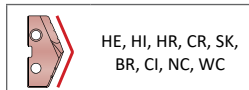
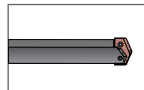
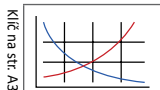

Klíč na str. A30: 1

Břitové destičky GEN2 T-A®

Série 3 | HSS | Rozsah průměrů: 34,36 mm - 47,80 mm (1.353" - 1.882")

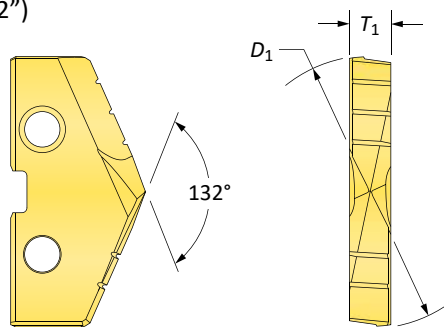

Destičky HSS – Premium Cobalt

| Destička | | | | Kód |
|----------|------------|-----------------|-----------|------------|
| D_1 mm | D_1 inch | Palců (zlomkem) | T_1 mm | TiN |
| 35.72 | 1.4063 | 1-13/32 | 6.35 | 483T-0113 |
| 36.00 | 1.4173 | - | | 483T-36 |
| 36.51 | 1.4375 | 1-7/16 | | 483T-0114 |
| 37.00 | 1.4567 | - | | 483T-37 |
| 37.31 | 1.4688 | 1-15/32 | | 483T-0115 |
| 38.00 | 1.4961 | - | | 483T-38 |
| 38.10 | 1.5000 | 1-1/2 | | 483T-0116 |
| 38.89 | 1.5313 | 1-17/32 | | 483T-0117 |
| 39.00 | 1.5354 | - | | 483T-39 |
| 39.29 | 1.5470 | - | | 483T-1.547 |
| 39.69 | 1.5625 | 1-9/16 | | 483T-0118 |
| 40.00 | 1.5748 | - | | 483T-40 |
| 40.48 | 1.5938 | 1-19/32 | | 483T-0119 |
| 41.00 | 1.6142 | - | | 483T-41 |
| 41.28 | 1.6250 | 1-5/8 | | 483T-0120 |
| 42.00 | 1.6535 | - | | 483T-42 |
| 42.07 | 1.6563 | 1-21/32 | | 483T-0121 |
| 42.86 | 1.6875 | 1-11/16 | | 483T-0122 |
| 43.00 | 1.6929 | - | | 483T-43 |
| 43.66 | 1.7188 | 1-23/32 | | 483T-0123 |
| 44.00 | 1.7323 | - | | 483T-44 |
| 44.45 | 1.7500 | 1-3/4 | | 483T-0124 |
| 45.00 | 1.7717 | - | | 483T-45 |
| 45.24 | 1.7813 | 1-25/32 | | 483T-0125 |
| 45.50 | 1.7913 | - | | 483T-45.5 |
| 45.64 | 1.7970 | - | | 483T-1.797 |
| 46.00 | 1.8110 | - | | 483T-46 |
| 46.04 | 1.8125 | 1-13/16 | | 483T-0126 |
| 46.83 | 1.8438 | 1-27/32 | 483T-0127 | |
| 47.00 | 1.8504 | - | 483T-47 | |
| 47.63 | 1.8750 | 1-7/8 | 483T-0128 | |

A30: 114 - 145

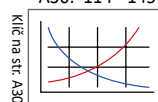

A30: 82 - 85

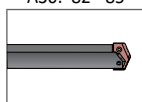

A30: 4 - 6

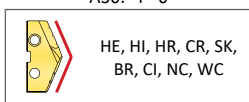

 Položky s povlaky
neuvezenými výše jsou
dodávány jako nestandardní.

| | |
|------------------|--------------------|
| TiN = 131T-XXXX | TiAlN = 131A-XXXX |
| TiCN = 131N-XXXX | AM200® = 131H-XXXX |

Destičky se dodávají po 1 ks

Břítové destičky T-A® Original

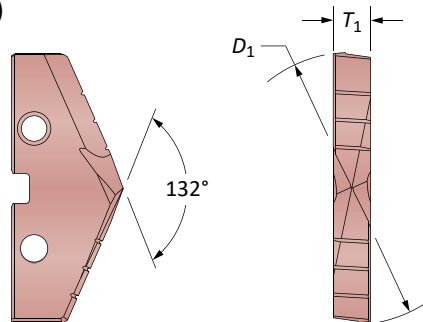
Série 3 | HSS | Rozsah průměrů: 34,36 mm - 47,80 mm (1.353" - 1.882")



Destičky HSS – Super Cobalt

| Destička | | | | Kód |
|----------|------------|-----------------|-----------|------------|
| D_1 mm | D_1 inch | Palců (zlomkem) | T_1 mm | AM200® |
| 35.72 | 1.4063 | 1-13/32 | 6.35 | 153H-0113 |
| 36.00 | 1.4173 | - | | 153H-36 |
| 36.51 | 1.4375 | 1-7/16 | | 153H-0114 |
| 37.00 | 1.4567 | - | | 153H-37 |
| 37.31 | 1.4688 | 1-15/32 | | 153H-0115 |
| 38.00 | 1.4961 | - | | 153H-38 |
| 38.10 | 1.5000 | 1-1/2 | | 153H-0116 |
| 38.89 | 1.5313 | 1-17/32 | | 153H-0117 |
| 39.00 | 1.5354 | - | | 153H-39 |
| 39.29 | 1.5470 | - | | 153H-1.547 |
| 39.69 | 1.5625 | 1-9/16 | | 153H-0118 |
| 40.00 | 1.5748 | - | | 153H-40 |
| 40.48 | 1.5938 | 1-19/32 | | 153H-0119 |
| 41.00 | 1.6142 | - | | 153H-41 |
| 41.28 | 1.6250 | 1-5/8 | | 153H-0120 |
| 42.00 | 1.6535 | - | | 153H-42 |
| 42.07 | 1.6563 | 1-21/32 | | 153H-0121 |
| 42.86 | 1.6875 | 1-11/16 | | 153H-0122 |
| 43.00 | 1.6929 | - | | 153H-43 |
| 43.66 | 1.7188 | 1-23/32 | | 153H-0123 |
| 44.00 | 1.7323 | - | | 153H-44 |
| 44.45 | 1.7500 | 1-3/4 | | 153H-0124 |
| 45.00 | 1.7717 | - | | 153H-45 |
| 45.24 | 1.7813 | 1-25/32 | | 153H-0125 |
| 45.50 | 1.7913 | - | | 153H-45.5 |
| 45.64 | 1.7970 | - | | 153H-1.797 |
| 46.00 | 1.8110 | - | | 153H-46 |
| 46.04 | 1.8125 | 1-13/16 | | 153H-0126 |
| 46.83 | 1.8438 | 1-27/32 | | 153H-0127 |
| 47.00 | 1.8504 | - | | 153H-47 |
| 47.63 | 1.8750 | 1-7/8 | 153H-0128 | |

A30: 114 - 145

A30: 82 - 85

A30: 4 - 6

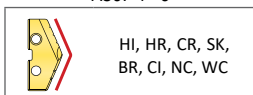
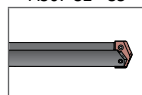
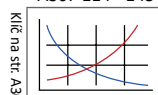

Položky s povlaky neuvedenými výše jsou dodávány jako nestandardní.



Destičky se dodávají po 1 ks

| | |
|------------------|--------------------|
| TIN = 131T-XXXX | TiAIN = 131A-XXXX |
| TiCN = 131N-XXXX | AM200® = 131H-XXXX |



**Břitové destičky T-A® Original**

Série 3 | HSS | Rozsah průměrů: 34,36 mm - 47,80 mm (1.353" - 1.882")

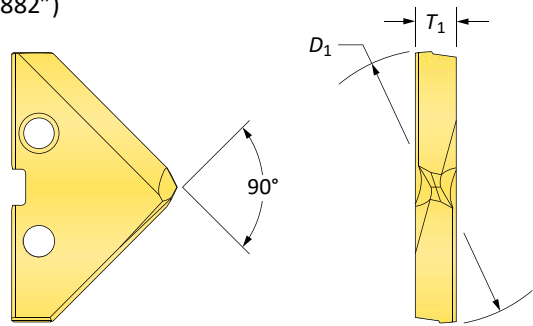

90° Spot & Chamfer

**Destičky HSS – Super Cobalt**

| Destička | | | | Kód | | |
|----------|------------|--------------------|----------|--|---|--|
| D_1 mm | D_1 inch | Palců (zlomkem) | T_1 mm |  TiN |  TiAlN |  TiCN |
| 35.72 | 1.4063 | 1-13/32 | 6.35 | 153T-0113-SP | 153A-0113-SP | 153N-0113-SP |
| 36.00 | 1.4173 | - | | 153T-36-SP | 153A-36-SP | 153N-36-SP |
| 36.51 | 1.4375 | 1-7/16 | | 153T-0114-SP | 153A-0114-SP | 153N-0114-SP |
| 37.00 | 1.4567 | - | | 153T-37-SP | 153A-37-SP | 153N-37-SP |
| 37.31 | 1.4688 | 1-15/32 | | 153T-0115-SP | 153A-0115-SP | 153N-0115-SP |
| 38.00 | 1.4961 | - | | 153T-38-SP | 153A-38-SP | 153N-38-SP |
| 38.10 | 1.5000 | 1-1/2 | | 153T-0116-SP | 153A-0116-SP | 153N-0116-SP |
| 38.89 | 1.5313 | 1-17/32 | | 153T-0117-SP | 153A-0117-SP | 153N-0117-SP |
| 39.00 | 1.5354 | - | | 153T-39-SP | 153A-39-SP | 153N-39-SP |
| 39.29 | 1.5470 | - | | 153T-1.547-SP | 153A-1.547-SP | 153N-1.547-SP |
| 39.69 | 1.5625 | 1-9/16 | | 153T-0118-SP | 153A-0118-SP | 153N-0118-SP |
| 40.00 | 1.5748 | - | | 153T-40-SP | 153A-40-SP | 153N-40-SP |
| 40.48 | 1.5938 | 1-19/32 | | 153T-0119-SP | 153A-0119-SP | 153N-0119-SP |
| 41.00 | 1.6142 | - | | 153T-41-SP | 153A-41-SP | 153N-41-SP |
| 41.28 | 1.6250 | 1-5/8 | | 153T-0120-SP | 153A-0120-SP | 153N-0120-SP |
| 42.00 | 1.6535 | - | | 153T-42-SP | 153A-42-SP | 153N-42-SP |
| 42.07 | 1.6563 | 1-21/32 | | 153T-0121-SP | 153A-0121-SP | 153N-0121-SP |
| 42.86 | 1.6875 | 1-11/16 | | 153T-0122-SP | 153A-0122-SP | 153N-0122-SP |
| 43.00 | 1.6929 | - | | 153T-43-SP | 153A-43-SP | 153N-43-SP |
| 43.66 | 1.7188 | 1-23/32 | | 153T-0123-SP | 153A-0123-SP | 153N-0123-SP |
| 44.00 | 1.7323 | - | | 153T-44-SP | 153A-44-SP | 153N-44-SP |
| 44.45 | 1.7500 | 1-3/4 | | 153T-0124-SP | 153A-0124-SP | 153N-0124-SP |
| 45.00 | 1.7717 | - | | 153T-45-SP | 153A-45-SP | 153N-45-SP |
| 45.24 | 1.7813 | 1-25/32 | | 153T-0125-SP | 153A-0125-SP | 153N-0125-SP |
| 45.50 | 1.7913 | - | | 153T-45.5-SP | 153A-45.5-SP | 153N-45.5-SP |
| 45.64 | 1.7970 | - | | 153T-1.797-SP | 153A-1.797-SP | 153N-1.797-SP |
| 46.00 | 1.8110 | - | | 153T-46-SP | 153A-46-SP | 153N-46-SP |
| 46.04 | 1.8125 | 1-13/16 | | 153T-0126-SP | 153A-0126-SP | 153N-0126-SP |
| 46.83 | 1.8438 | 1-27/32 | | 153T-0127-SP | 153A-0127-SP | 153N-0127-SP |
| 47.00 | 1.8504 | - | | 153T-47-SP | 153A-47-SP | 153N-47-SP |
| 47.63 | 1.8750 | 1-7/8 | | 153T-0128-SP | 153A-0128-SP | 153N-0128-SP |

Destičky se dodávají po 1 ks

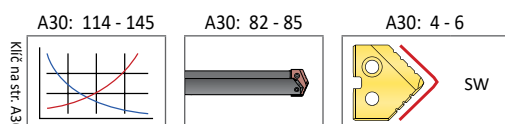

Položky s povlaky
neuvedenými výše jsou
dodávány jako nestandardní.



| | |
|------------------|--------------------|
| TiN = 131T-XXXX | TiAlN = 131A-XXXX |
| TiCN = 131N-XXXX | AM200® = 131H-XXXX |

Břítové destičky T-A® Original

Série 3 | HSS | Rozsah průměrů: 34,36 mm - 47,80 mm (1.353" - 1.882")



Rovné dno (FB)

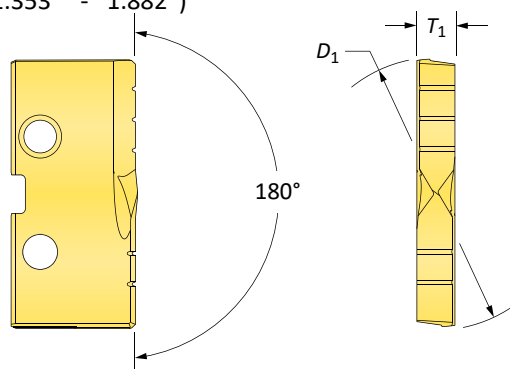

Destičky HSS – Super Cobalt

| Destička | | | T ₁ mm | Kód |
|-------------------|---------------------|-----------------|-------------------|---------------|
| D ₁ mm | D ₁ inch | Palců (zlomkem) | | TiN |
| 35.72 | 1.4063 | 1-13/32 | 6.35 | 153T-0113-FB |
| 36.00 | 1.4173 | - | | 153T-36-FB |
| 36.51 | 1.4375 | 1-7/16 | | 153T-0114-FB |
| 37.00 | 1.4567 | - | | 153T-37-FB |
| 37.31 | 1.4688 | 1-15/32 | | 153T-0115-FB |
| 38.00 | 1.4961 | - | | 153T-38-FB |
| 38.10 | 1.5000 | 1-1/2 | | 153T-0116-FB |
| 38.89 | 1.5313 | 1-17/32 | | 153T-0117-FB |
| 39.00 | 1.5354 | - | | 153T-39-FB |
| 39.29 | 1.5470 | - | | 153T-1.547-FB |
| 39.69 | 1.5625 | 1-9/16 | | 153T-0118-FB |
| 40.00 | 1.5748 | - | | 153T-40-FB |
| 40.48 | 1.5938 | 1-19/32 | | 153T-0119-FB |
| 41.00 | 1.6142 | - | | 153T-41-FB |
| 41.28 | 1.6250 | 1-5/8 | | 153T-0120-FB |
| 42.00 | 1.6535 | - | | 153T-42-FB |
| 42.07 | 1.6563 | 1-21/32 | | 153T-0121-FB |
| 42.86 | 1.6875 | 1-11/16 | | 153T-0122-FB |
| 43.00 | 1.6929 | - | | 153T-43-FB |
| 43.66 | 1.7188 | 1-23/32 | | 153T-0123-FB |
| 44.00 | 1.7323 | - | | 153T-44-FB |
| 44.45 | 1.7500 | 1-3/4 | | 153T-0124-FB |
| 45.00 | 1.7717 | - | | 153T-45-FB |
| 45.24 | 1.7813 | 1-25/32 | | 153T-0125-FB |
| 45.50 | 1.7913 | - | | 153T-45.5-FB |
| 45.64 | 1.7970 | - | | 153T-1.797-FB |
| 46.00 | 1.8110 | - | | 153T-46-FB |
| 46.04 | 1.8125 | 1-13/16 | | 153T-0126-FB |
| 46.83 | 1.8438 | 1-27/32 | 153T-0127-FB | |
| 47.00 | 1.8504 | - | 153T-47-FB | |
| 47.63 | 1.8750 | 1-7/8 | 153T-0128-FB | |

Destičky se dodávají po 1 ks

Položky s povlaky neuvedenými výše jsou dodávány jako nestandardní.



| | |
|------------------|--------------------|
| TiN = 131T-XXXX | TiAlN = 131A-XXXX |
| TiCN = 131N-XXXX | AM200® = 131H-XXXX |

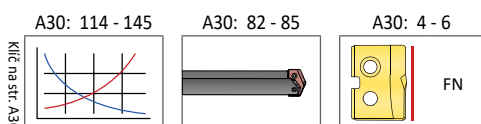

Klíč na str. A30: 1

Břitové destičky T-A® Original

Série 3 | Karbidové | Rozsah průměrů: 34,36 mm - 47,80 mm (1.353" - 1.882")

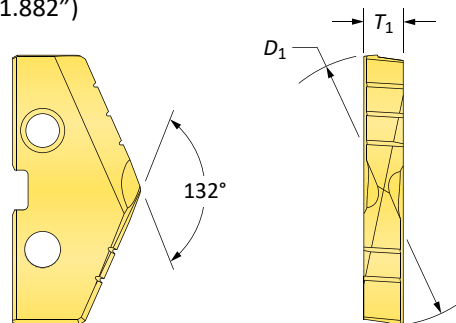

Karbidové destičky – K20 (C2)

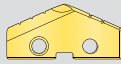
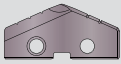
| Destička | | | T ₁ mm | Kód | |
|-------------------|---------------------|-----------------|-------------------|---|---|
| D ₁ mm | D ₁ inch | Palců (zlomkem) | |  TiN |  TiAlN |
| 35.72 | 1.4063 | 1-13/32 | 6.35 | 1C23T-0113 | 1C23A-0113 |
| 36.00 | 1.4173 | – | | 1C23T-36 | 1C23A-36 |
| 36.51 | 1.4375 | 1-7/16 | | 1C23T-0114 | 1C23A-0114 |
| 37.00 | 1.4567 | – | | 1C23T-37 | 1C23A-37 |
| 37.31 | 1.4688 | 1-15/32 | | 1C23T-0115 | 1C23A-0115 |
| 38.00 | 1.4961 | – | | 1C23T-38 | 1C23A-38 |
| 38.10 | 1.5000 | 1-1/2 | | 1C23T-0116 | 1C23A-0116 |
| 38.89 | 1.5313 | 1-17/32 | | 1C23T-0117 | 1C23A-0117 |
| 39.00 | 1.5354 | – | | 1C23T-39 | 1C23A-39 |
| 39.29 | 1.5470 | – | | 1C23T-1.547 | 1C23A-1.547 |
| 39.69 | 1.5625 | 1-9/16 | | 1C23T-0118 | 1C23A-0118 |
| 40.00 | 1.5748 | – | | 1C23T-40 | 1C23A-40 |
| 40.48 | 1.5938 | 1-19/32 | | 1C23T-0119 | 1C23A-0119 |
| 41.00 | 1.6142 | – | | 1C23T-41 | 1C23A-41 |
| 41.28 | 1.6250 | 1-5/8 | | 1C23T-0120 | 1C23A-0120 |
| 42.00 | 1.6535 | – | | 1C23T-42 | 1C23A-42 |
| 42.07 | 1.6563 | 1-21/32 | | 1C23T-0121 | 1C23A-0121 |
| 42.86 | 1.6875 | 1-11/16 | | 1C23T-0122 | 1C23A-0122 |
| 43.00 | 1.6929 | – | | 1C23T-43 | 1C23A-43 |
| 43.66 | 1.7188 | 1-23/32 | | 1C23T-0123 | 1C23A-0123 |
| 44.00 | 1.7323 | – | | 1C23T-44 | 1C23A-44 |
| 44.45 | 1.7500 | 1-3/4 | | 1C23T-0124 | 1C23A-0124 |
| 45.00 | 1.7717 | – | | 1C23T-45 | 1C23A-45 |
| 45.24 | 1.7813 | 1-25/32 | | 1C23T-0125 | 1C23A-0125 |
| 45.50 | 1.7913 | – | | 1C23T-45.5 | 1C23A-45.5 |
| 45.64 | 1.7970 | – | | 1C23T-1.797 | 1C23A-1.797 |
| 46.00 | 1.8110 | – | | 1C23T-46 | 1C23A-46 |
| 46.04 | 1.8125 | 1-13/16 | | 1C23T-0126 | 1C23A-0126 |
| 46.83 | 1.8438 | 1-27/32 | 1C23T-0127 | 1C23A-0127 | |
| 47.00 | 1.8504 | – | 1C23T-47 | 1C23A-47 | |
| 47.63 | 1.8750 | 1-7/8 | 1C23T-0128 | 1C23A-0128 | |

Destičky se dodávají po 1 ks

A30: 114 - 145

A30: 82 - 85

A30: 4 - 6

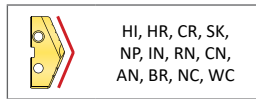
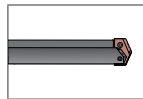
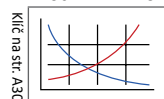

Položky s povlaky
neuvedenými výše jsou
dodávány jako
nestandardní.



| | |
|-------------------------|---------------------------|
| TiN = 131T-XXXX | TiAlN = 131A-XXXX |
| TiCN = 131N-XXXX | AM200® = 131H-XXXX |

Břítové destičky T-A® Original

Série 3 | HSS | Rozsah průměrů: 34,36 mm - 47,80 mm (1.353" - 1.882")

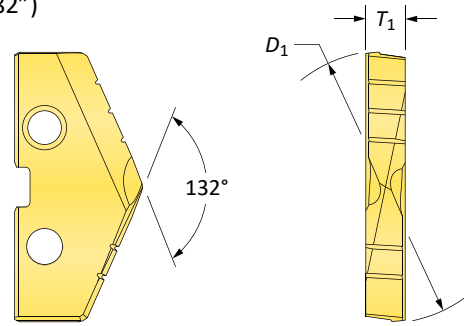

Karbidové destičky – P35 (C5)

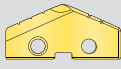
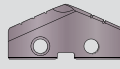
| Destička | | | | Kód | |
|----------|------------|--------------------|------------|---|---|
| D_1 mm | D_1 inch | Palců (zlomkem) | T_1 mm |  TiN |  TiAlN |
| 35.72 | 1.4063 | 1-13/32 | 6.35 | 1C53T-0113 | 1C53A-0113 |
| 36.00 | 1.4173 | – | | 1C53T-36 | 1C53A-36 |
| 36.51 | 1.4375 | 1-7/16 | | 1C53T-0114 | 1C53A-0114 |
| 37.00 | 1.4567 | – | | 1C53T-37 | 1C53A-37 |
| 37.31 | 1.4688 | 1-15/32 | | 1C53T-0115 | 1C53A-0115 |
| 38.00 | 1.4961 | – | | 1C53T-38 | 1C53A-38 |
| 38.10 | 1.5000 | 1-1/2 | | 1C53T-0116 | 1C53A-0116 |
| 38.89 | 1.5313 | 1-17/32 | | 1C53T-0117 | 1C53A-0117 |
| 39.00 | 1.5354 | – | | 1C53T-39 | 1C53A-39 |
| 39.29 | 1.5470 | – | | 1C53T-1.547 | 1C53A-1.547 |
| 39.69 | 1.5625 | 1-9/16 | | 1C53T-0118 | 1C53A-0118 |
| 40.00 | 1.5748 | – | | 1C53T-40 | 1C53A-40 |
| 40.48 | 1.5938 | 1-19/32 | | 1C53T-0119 | 1C53A-0119 |
| 41.00 | 1.6142 | – | | 1C53T-41 | 1C53A-41 |
| 41.28 | 1.6250 | 1-5/8 | | 1C53T-0120 | 1C53A-0120 |
| 42.00 | 1.6535 | – | | 1C53T-42 | 1C53A-42 |
| 42.07 | 1.6563 | 1-21/32 | | 1C53T-0121 | 1C53A-0121 |
| 42.86 | 1.6875 | 1-11/16 | | 1C53T-0122 | 1C53A-0122 |
| 43.00 | 1.6929 | – | | 1C53T-43 | 1C53A-43 |
| 43.66 | 1.7188 | 1-23/32 | | 1C53T-0123 | 1C53A-0123 |
| 44.00 | 1.7323 | – | | 1C53T-44 | 1C53A-44 |
| 44.45 | 1.7500 | 1-3/4 | | 1C53T-0124 | 1C53A-0124 |
| 45.00 | 1.7717 | – | | 1C53T-45 | 1C53A-45 |
| 45.24 | 1.7813 | 1-25/32 | | 1C53T-0125 | 1C53A-0125 |
| 45.50 | 1.7913 | – | | 1C53T-45.5 | 1C53A-45.5 |
| 45.64 | 1.7970 | – | | 1C53T-1.797 | 1C53A-1.797 |
| 46.00 | 1.8110 | – | | 1C53T-46 | 1C53A-46 |
| 46.04 | 1.8125 | 1-13/16 | | 1C53T-0126 | 1C53A-0126 |
| 46.83 | 1.8438 | 1-27/32 | 1C53T-0127 | 1C53A-0127 | |
| 47.00 | 1.8504 | – | 1C53T-47 | 1C53A-47 | |
| 47.63 | 1.8750 | 1-7/8 | 1C53T-0128 | 1C53A-0128 | |

A30: 114 - 145

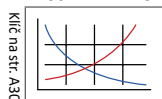

A30: 82 - 85

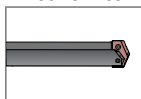

A30: 4 - 6



HI, HR, CR, SK,
NP, IN, RN, CN,
AN, BR, NC, WC

Položky s povlaky
neuvedenými výše jsou
dodávány jako nestandardní.

| | |
|------------------|--------------------|
| TiN = 131T-XXXX | TiAlN = 131A-XXXX |
| TiCN = 131N-XXXX | AM200® = 131H-XXXX |

Destičky se dodávají po 1 ks

Klíč na str. A30: 1

Držáky břitových destiček T-A®

Série 3 | Válcová stopka s ploškou

A

VRTÁNÍ

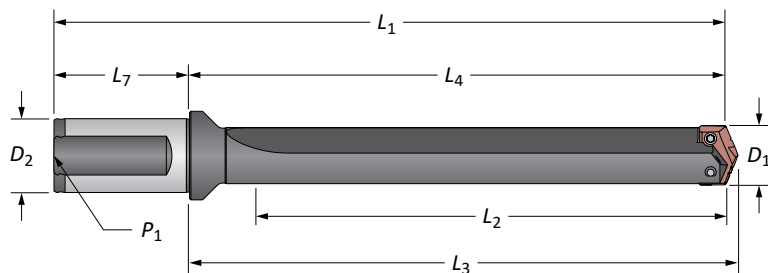

B

VVRTÁVÁNÍ



Velmi krátké

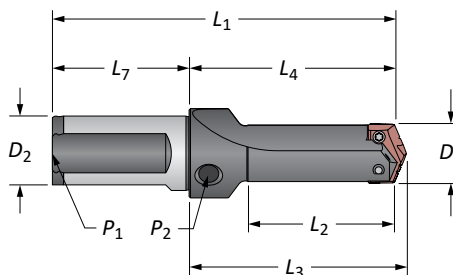

C

VYSTRUŽOVÁNÍ

Přímá drážka

| Délka | D ₁ | Tělo nástroje | | | | Stopka | | | Kód |
|--------------|-----------------|----------------|----------------|----------------|----------------|----------------|----------------|----------------|-------------|
| | | L ₂ | L ₄ | L ₃ | L ₁ | D ₂ | L ₇ | P ₁ | |
| Velmi krátké | 36.0 - 47.0 | 76.2 | 125.0 | 129.8 | 195.0 | 40.0 | 70.0 | 1/4* | 21030S-40FM |
| Krátké | 36.0 - 47.0 | 120.7 | 173.0 | 177.8 | 243.0 | 40.0 | 70.0 | 1/4* | 22030S-40FM |
| Prodloužené | 36.0 - 47.0 | 349.3 | 401.6 | 406.4 | 471.6 | 40.0 | 70.0 | 1/4* | 25030S-40FM |
| XL | 36.0 - 47.0 | 558.8 | 611.1 | 615.9 | 681.1 | 40.0 | 70.0 | 1/4* | 27030S-40FM |
| 3XL | 36.0 - 47.0 | 787.4 | 839.7 | 844.5 | 909.7 | 40.0 | 70.0 | 1/4* | 29030S-40FM |
| Velmi krátké | 1-13/32 - 1-7/8 | 3 | 4-59/64 | 5-7/64 | 7-39/64 | 1-1/2 | 2-11/16 | 1/4 | 21030S-150F |
| Krátké | 1-13/32 - 1-7/8 | 4-3/4 | 6-13/16 | 7 | 9-1/2 | 1-1/2 | 2-11/16 | 1/4 | 22030S-150F |
| Střední | 1-13/32 - 1-7/8 | 6-1/2 | 8-9/16 | 8-3/4 | 11-1/4 | 1-1/2 | 2-11/16 | 1/4 | 23030S-150F |
| Standard | 1-13/32 - 1-7/8 | 8-1/4 | 10-5/16 | 10-1/2 | 13 | 1-1/2 | 2-11/16 | 1/4 | 24030S-150F |

*Metrický závit BSP / ISO 7-1

POZNÁMKA: Velmi krátké držáky mají postranní vývod 1/4" (P₂)

D VÁLEČKOVÁNÍ

E

ZÁVITOVÁNÍ

Příslušenství

| Šrouby | Šrouby s nylon. jištěním | Šroubovák | Momentový šroubovák | Vyměnitelné hroty | * Přípustný utahovací moment |
|-------------|--------------------------|-----------|---------------------|-------------------|------------------------------|
| 7514-IP20-1 | 7514N-IP20-1 | 8IP-20 | 8IP-20TL | 8IP-20B | 1370 N/cm (121.3 in-lbs) |

* Uťahovací momenty se počítají s koeficientem tření $\mu = 0,14$ a představují 90 % meze kluzu

X

OSTATNÍ

A30: 74 - 81

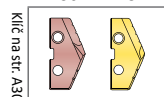

POZOR!

Doporučené hodnoty rychlostí a posuvů najdete v příslušných grafech. Pokyny pro hluboké vrtání najdete v této části katalogu na stránce A30: 148. Aktuální informace a postupy najdete na www.alliedmachine.com. Technická podpora pro vaše konkrétní aplikace je k dispozici prostřednictvím našich aplikačních techniků.

m = Metrický (mm)

i = Palcový (in)

Šrouby se dodávají po 10 ks

Držáky břitových destiček T-A®

Série 3 | Válcová stopka s ploškou

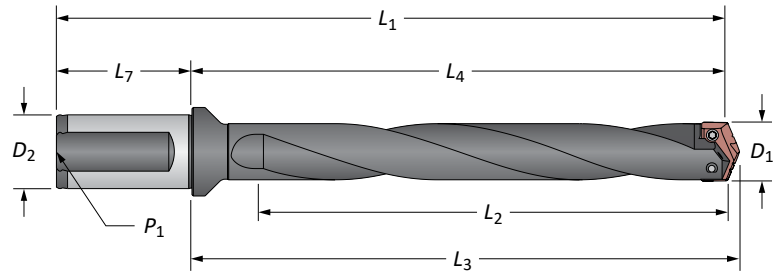

Drážka ve šroubovici

| Délka | D ₁ | Tělo nástroje | | | | Stopka | | | Kód | |
|-------|----------------|-----------------|----------------|----------------|----------------|----------------|----------------|----------------|------|-------------|
| | | L ₂ | L ₄ | L ₃ | L ₁ | D ₂ | L ₇ | P ₁ | | |
| m | Střední | 36.0 - 47.0 | 165.1 | 217.5 | 222.3 | 287.5 | 40.0 | 70.0 | 1/4* | 23030H-40FM |
| | Standard | 36.0 - 47.0 | 209.6 | 261.9 | 266.7 | 331.9 | 40.0 | 70.0 | 1/4* | 24030H-40FM |
| i | Střední | 1-13/32 - 1-7/8 | 6-1/2 | 8-9/16 | 8-3/4 | 11-1/4 | 1-1/2 | 2-11/16 | 1/4 | 23030H-150F |
| | Standard | 1-13/32 - 1-7/8 | 8-1/4 | 10-5/16 | 10-1/2 | 13 | 1-1/2 | 2-11/16 | 1/4 | 24030H-150F |

*Metrický závit BSP / ISO 7-1

Příslušenství

| | | | | | |
|-------------|--------------------------|-----------|---------------------|-------------------|-------------------------------------|
| | | | | | * Přípustný utahovací moment |
| Šrouby | Šrouby s nylon. jištěním | Šroubovák | Momentový šroubovák | Vyměnitelné hroty | |
| 7514-IP20-1 | 7514N-IP20-1 | 8IP-20 | 8IP-20TL | 8IP-20B | 1370 N/cm (121.3 in-lbs) |

* Uťahovací momenty se počítají s koeficientem tření $\mu = 0,14$ a představují 90 % meze kluzu

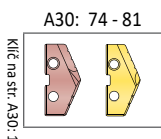

Ⓜ = Metrický (mm)
i = Palcový (in)

Šrouby se dodávají po 10 ks

A VRTÁNÍ
B VYVRTÁVÁNÍ
C VYSTRUŽOVÁNÍ
D VÁLEČKOVÁNÍ
E ZÁVITOVÁNÍ
X OSTATNÍ



Držáky břitových destiček T-A®

Série 3 | S kuželovou stopkou

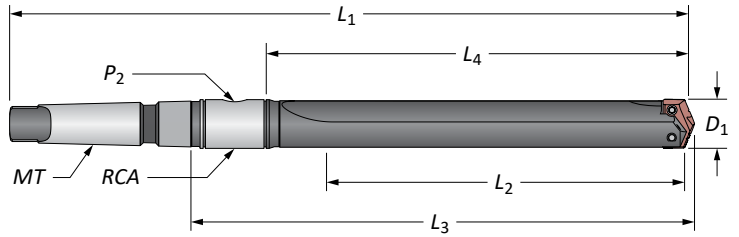

Přímá drážka

| Délka | D ₁ | Tělo nástroje | | | | | Stopka | | | Kód |
|-------------|-----------------|----------------|----------------|----------------|----------------|------|----------------|---------|-------------|-----|
| | | L ₂ | L ₄ | L ₃ | L ₁ | MT | P ₂ | RCA | | |
| Krátké | 36.0 - 47.0 | 120.6 | 152.4 | 206.4 | 319.1 | #4** | 1/4* | 2T-4SRM | 22030S-004M | |
| Prodloužené | 36.0 - 47.0 | 349.3 | 381.0 | 435.0 | 547.7 | #4** | 1/4* | 2T-4SRM | 25030S-004M | |
| XL | 36.0 - 47.0 | 558.8 | 590.6 | 644.6 | 757.2 | #4** | 1/4* | 2T-4SRM | 27030S-004M | |
| 3XL | 36.0 - 47.0 | 787.4 | 819.2 | 873.2 | 985.8 | #4** | 1/4* | 2T-4SRM | 29030S-004M | |
| Krátké | 1-13/32 - 1-7/8 | 4-3/4 | 6 | 8-1/8 | 12-9/16 | #4 | 1/4 | 2T-4SR | 22030S-004I | |
| Krátké | 1-13/32 - 1-7/8 | 4-3/4 | 6 | 8-1/8 | 13-13/16 | #5 | 1/4 | 2T-5SR | 22030S-005I | |
| Střední | 1-13/32 - 1-7/8 | 6-1/2 | 7-3/4 | 9-7/8 | 14-5/16 | #4 | 1/4 | 2T-4SR | 23030S-004I | |
| Standard | 1-13/32 - 1-7/8 | 8-1/4 | 9-1/2 | 11-5/8 | 16-1/16 | #4 | 1/4 | 2T-4SR | 24030S-004I | |
| Standard | 1-13/32 - 1-7/8 | 8-1/4 | 9-1/2 | 11-5/8 | 17-5/16 | #5 | 1/4 | 2T-5SR | 24030S-005I | |
| Prodloužené | 1-13/32 - 1-7/8 | 13-3/4 | 15 | 17-1/8 | 21-9/16 | #4 | 1/4 | 2T-4SR | 25030S-004I | |
| XL | 1-13/32 - 1-7/8 | 22 | 22-1/4 | 25-3/8 | 29-13/16 | #4 | 1/4 | 2T-4SR | 27030S-004I | |
| 3XL | 1-13/32 - 1-7/8 | 31 | 32-1/4 | 34-3/8 | 38-13/16 | #4 | 1/4 | 2T-4SR | 29030S-004I | |

*Metrický závit BSP / ISO 7-1

**Pro ISO 296 typ BEK

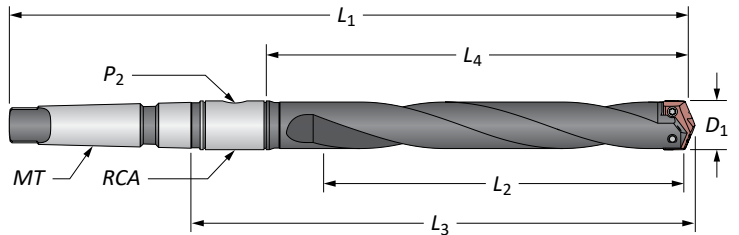

Drážka ve šroubovici

| Délka | D ₁ | Tělo nástroje | | | | | Stopka | | | Kód |
|----------|----------------|----------------|----------------|----------------|----------------|----|----------------|---------|-------------|-----|
| | | L ₂ | L ₃ | L ₄ | L ₁ | MT | P ₂ | RCA | | |
| Střední | 36.0 - 47.0 | 165.1 | 196.9 | 250.9 | 363.6 | #4 | 1/4* | 2T-4SRM | 23030H-004M | |
| Standard | 36.0 - 47.0 | 209.5 | 241.3 | 295.3 | 408.0 | #4 | 1/4* | 2T-4SRM | 24030H-004M | |

*Metrický závit BSP / ISO 7-1 |

**Pro ISO 296 typ BEK

Příslušenství

| Šrouby | Šrouby s nylon. jištěním | Šroubovák | Momentový šroubovák | Vyměnitelné hroty | * Přípustný utahovací moment |
|-------------|--------------------------|-----------|---------------------|-------------------|------------------------------|
| 7514-IP20-1 | 7514N-IP20-1 | 8IP-20 | 8IP-20TL | 8IP-20B | 1370 N/cm (121.3 in-lbs) |

* Uťahovací momenty se počítají s koeficientem tření $\mu = 0,14$ a představují 90 % meze kluzu

A30: 74 - 81

A30: 85 & 111

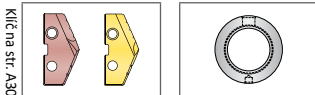

Ⓜ = Metrický (mm)

Ⓜ = Palcový (in)

Šrouby se dodávají po 10 ks

POZOR! Doporučené hodnoty rychlostí a posuvů najdete v příslušných grafech. Pokyny pro hluboké vrtání najdete v této části katalogu na stránce A30: 148. Aktuální informace a postupy najdete na www.alliedmachine.com. Technická podpora pro vaše konkrétní aplikace je k dispozici prostřednictvím našich aplikačních techniků.

Držáky břitových destiček T-A®

Série 3 | Válcová stopka

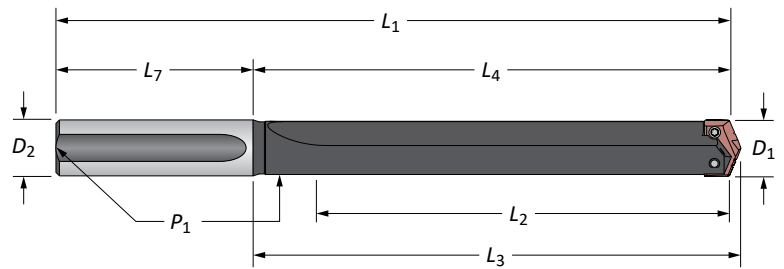

Přímá drážka

| Délka | D ₁ | Tělo nástroje | | | | Stopka | | | Kód |
|-------------|-----------------|----------------|----------------|----------------|----------------|----------------|----------------|----------------|-------------|
| | | L ₂ | L ₄ | L ₃ | L ₁ | D ₂ | L ₇ | P ₁ | |
| Krátké | 1-13/32 - 1-7/8 | 4-3/4 | 6 | 6-3/16 | 10 | 1-1/4 | 4 | 1/4 | 22030S-125L |
| Krátké | 1-13/32 - 1-7/8 | 4-3/4 | 6 | 6-3/16 | 10 | 1-1/2 | 4 | 1/4 | 22030S-150L |
| Střední | 1-13/32 - 1-7/8 | 6-1/2 | 7-3/4 | 7-15/16 | 11-3/4 | 1-1/2 | 4 | 1/4 | 23030S-150L |
| Standard | 1-13/32 - 1-7/8 | 8-1/4 | 9-1/2 | 9-11/16 | 13-1/2 | 1-1/4 | 4 | 1/4 | 24030S-125L |
| Standard | 1-13/32 - 1-7/8 | 8-1/4 | 9-1/2 | 9-11/16 | 13-1/2 | 1-1/2 | 4 | 1/4 | 24030S-150L |
| Prodloužené | 1-13/32 - 1-7/8 | 13-3/4 | 15-3/16 | 15-3/16 | 19 | 1-1/4 | 4 | 1/4 | 25030S-125L |
| XL | 1-13/32 - 1-7/8 | 22 | 23-7/16 | 23-7/16 | 27-1/4 | 1-1/2 | 4 | 1/4 | 27030S-150L |
| 3XL | 1-13/32 - 1-7/8 | 31 | 32-7/16 | 32-7/16 | 36-1/4 | 1-1/2 | 4 | 1/4 | 29030S-150L |

Příslušenství držáků T-A®

Série 3 | Adaptéry pro přívod chladicí kapaliny | Šrouby Torx® Plus

Adaptéry pro přívod chladicí kapaliny (RCA)

| ID | OD | L ₁ | Závit přívodní trubice | P ₁ | Kód | O-kroužky RCA | |
|-------|-------|----------------|------------------------------|----------------|---------|---------------|----------------|
| | | | | | | Kód sady.** | Náhr. součásti |
| 31.75 | 63.50 | 34.92 | M10x1.50 | 1/4* | 2T-4SRM | 2T1-4SR | 2T1-4OR-10 |
| 44.45 | 76.20 | 34.92 | M10x1.50 | 1/4* | 2T-5SRM | 2T1-5SR | 2T1-5OR-10 |
| 1-1/4 | 2-1/2 | 1-3/8 | 3/8-16 | 1/4 | 2T-4SR | 2T1-4SR | 2T1-4OR-10 |
| 1-3/4 | 3 | 1-3/8 | 3/8-16 | 1/4 | 2T-5SR | 2T1-5SR | 2T1-5OR-10 |

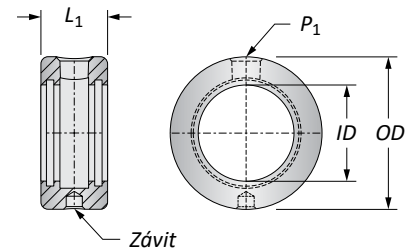

*Závit BSP a ISO 7-1

**RCA sada pro opravu obsahuje (2) O-kroužky, (2) pojistné kroužky

⚠ a (2) přítlačné podložky Na straně A30: 111 najdete pokyny pro sestavení a bezpečnostní informace

Příslušenství

| Šrouby | Šrouby s nylon. jištěním | Šroubovák | Momentový šroubovák | Vyměnitelné hroty | * Přípustný utahovací moment |
|-------------|--------------------------|-----------|---------------------|-------------------|------------------------------|
| 7514-IP20-1 | 7514N-IP20-1 | 8IP-20 | 8IP-20TL | 8IP-20B | 1370 N/cm (121.3 in-lbs) |

* Uťahovací momenty se počítají s koeficientem tření $\mu = 0,14$ a představují 90 % meze kluzu

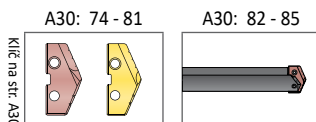

Ⓜ = Metrický (mm)

Ⓜ = Palcový (in)

Destičky se dodávají samostatně

Šrouby se dodávají po 10 ks

O-kroužky se dodávají po 10 ks

POZOR! Doporučené hodnoty rychlostí a posuvů najdete v příslušných grafech. Pokyny pro hluboké vrtání najdete v této části katalogu na stránce A30: 148. Aktuální informace a postupy najdete na www.alliedmachine.com. Technická podpora pro vaše konkrétní konkrétní aplikace je k dispozici prostřednictvím našich aplikačních techniků.