

Karbidové břitové destičky T-A Pro

Série 3 | Rozsah průměrů: 35.05 mm - 47.80 mm

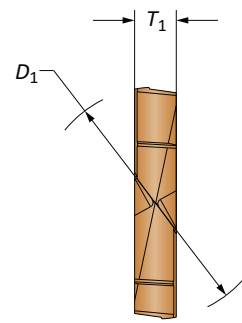
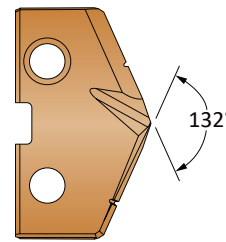

Destička							
Série	D ₁ mm	D ₁ palců	Zlomkové vyjádření	T ₁ mm	Obj. číslo P	Obj. číslo K	Obj. číslo N
3-A	35.72	1.4063	1-13/32	6.35	TAP3-35.72	TAK3-35.72	TAN3-35.72
3-A	35.80	1.4094		6.35	TAP3-35.80	TAK3-35.80	TAN3-35.80
3-A	35.90	1.4134		6.35	TAP3-35.90	TAK3-35.90	TAN3-35.90
3-A	36.00	1.4173		6.35	TAP3-36.00	TAK3-36.00	TAN3-36.00
3-A	36.10	1.4213		6.35	TAP3-36.10	TAK3-36.10	TAN3-36.10
3-A	36.20	1.4252		6.35	TAP3-36.20	TAK3-36.20	TAN3-36.20
3-A	36.30	1.4291		6.35	TAP3-36.30	TAK3-36.30	TAN3-36.30
3-A	36.40	1.4331		6.35	TAP3-36.40	TAK3-36.40	TAN3-36.40
3-A	36.50	1.4370		6.35	TAP3-36.50	TAK3-36.50	TAN3-36.50
3-A	36.51	1.4374	1-7/16	6.35	TAP3-36.51	TAK3-36.51	TAN3-36.51
3-A	36.60	1.4409		6.35	TAP3-36.60	TAK3-36.60	TAN3-36.60
3-A	36.70	1.4449		6.35	TAP3-36.70	TAK3-36.70	TAN3-36.70
3-A	36.80	1.4488		6.35	TAP3-36.80	TAK3-36.80	TAN3-36.80
3-A	36.90	1.4528		6.35	TAP3-36.90	TAK3-36.90	TAN3-36.90
3-A	37.00	1.4567		6.35	TAP3-37.00	TAK3-37.00	TAN3-37.00
3-A	37.10	1.4606		6.35	TAP3-37.10	TAK3-37.10	TAN3-37.10
3-A	37.20	1.4646		6.35	TAP3-37.20	TAK3-37.20	TAN3-37.20
3-A	37.30	1.4685		6.35	TAP3-37.30	TAK3-37.30	TAN3-37.30
3-A	37.31	1.4689	1-15/32	6.35	TAP3-37.31	TAK3-37.31	TAN3-37.31
3-A	37.40	1.4724		6.35	TAP3-37.40	TAK3-37.40	TAN3-37.40
3-A	37.50	1.4764		6.35	TAP3-37.50	TAK3-37.50	TAN3-37.50
3-A	37.60	1.4803		6.35	TAP3-37.60	TAK3-37.60	TAN3-37.60
3-A	37.70	1.4843		6.35	TAP3-37.70	TAK3-37.70	TAN3-37.70

Destičky se dodávají v balení po 1 ks

Mezisérie držáků (A, B, C, D)

Jejich použití se doporučuje, pokud vrtáme karbidovými destičkami o průměru na horním konci příslušné série, nebo u aplikací náročných na tuhost systému.
POZNÁMKA: S mezisériovými držáky mohou být použity pouze specifikované destičky, se stejným nebo větším průměrem, než mají příslušné držáky.



Destička série A + Držák série A

Destička série C + Držák série A

Destička série C + Držák série C

Destička série A + Držák série C

A25: 50 - 53

A25: 48 - 49

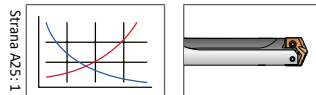

Neuvedené průměry na objednávku. Příklad objednávky:

Metrické: 13.16mm, ocel, Série 0 = Použijte obj. číslo TAP0-13.16

Palcové: 0.5180", ocel, Série 0 = Použijte obj. číslo TAP0-13.16

Karbidové břitové destičky T-A Pro

Série 3 | Rozsah průměrů: 35.05 mm - 47.80 mm

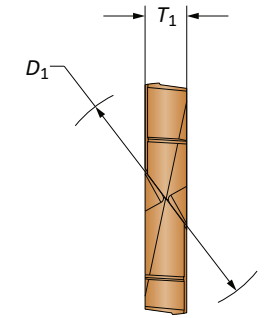
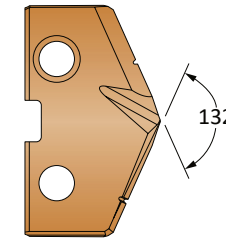

Destička							
Série	D ₁ mm	D ₁ palců	Zlomkové vyjádření	T ₁ mm	Obj. číslo P	Obj. číslo K	Obj. číslo N
3-B	37.80	1.4882		6.35	TAP3-37.80	TAK3-37.80	TAN3-37.80
3-B	37.90	1.4921		6.35	TAP3-37.90	TAK3-37.90	TAN3-37.90
3-B	38.00	1.4961		6.35	TAP3-38.00	TAK3-38.00	TAN3-38.00
3-B	38.10	1.5000	1-1/2	6.35	TAP3-38.10	TAK3-38.10	TAN3-38.10
3-B	38.20	1.5039		6.35	TAP3-38.20	TAK3-38.20	TAN3-38.20
3-B	38.30	1.5079		6.35	TAP3-38.30	TAK3-38.30	TAN3-38.30
3-B	38.40	1.5118		6.35	TAP3-38.40	TAK3-38.40	TAN3-38.40
3-B	38.50	1.5157		6.35	TAP3-38.50	TAK3-38.50	TAN3-38.50
3-B	38.60	1.5197		6.35	TAP3-38.60	TAK3-38.60	TAN3-38.60
3-B	38.70	1.5236		6.35	TAP3-38.70	TAK3-38.70	TAN3-38.70
3-B	38.80	1.5276		6.35	TAP3-38.80	TAK3-38.80	TAN3-38.80
3-B	38.89	1.5311	1-17/32	6.35	TAP3-38.89	TAK3-38.89	TAN3-38.89
3-B	38.90	1.5315		6.35	TAP3-38.90	TAK3-38.90	TAN3-38.90
3-B	39.00	1.5354		6.35	TAP3-39.00	TAK3-39.00	TAN3-39.00
3-B	39.10	1.5394		6.35	TAP3-39.10	TAK3-39.10	TAN3-39.10
3-B	39.20	1.5433		6.35	TAP3-39.20	TAK3-39.20	TAN3-39.20
3-B	39.29	1.5469		6.35	TAP3-39.29	TAK3-39.29	TAN3-39.29
3-B	39.30	1.5472		6.35	TAP3-39.30	TAK3-39.30	TAN3-39.30
3-B	39.40	1.5512		6.35	TAP3-39.40	TAK3-39.40	TAN3-39.40
3-B	39.50	1.5551		6.35	TAP3-39.50	TAK3-39.50	TAN3-39.50
3-B	39.60	1.5591		6.35	TAP3-39.60	TAK3-39.60	TAN3-39.60
3-B	39.69	1.5626	1-9/16	6.35	TAP3-39.69	TAK3-39.69	TAN3-39.69
3-B	39.70	1.5630		6.35	TAP3-39.70	TAK3-39.70	TAN3-39.70
3-B	39.80	1.5669		6.35	TAP3-39.80	TAK3-39.80	TAN3-39.80
3-B	39.90	1.5709		6.35	TAP3-39.90	TAK3-39.90	TAN3-39.90
3-B	40.00	1.5748		6.35	TAP3-40.00	TAK3-40.00	TAN3-40.00
3-B	40.10	1.5787		6.35	TAP3-40.10	TAK3-40.10	TAN3-40.10
3-B	40.20	1.5827		6.35	TAP3-40.20	TAK3-40.20	TAN3-40.20
3-B	40.30	1.5866		6.35	TAP3-40.30	TAK3-40.30	TAN3-40.30
3-B	40.40	1.5906		6.35	TAP3-40.40	TAK3-40.40	TAN3-40.40
3-B	40.48	1.5937	1-19/32	6.35	TAP3-40.48	TAK3-40.48	TAN3-40.48
3-B	40.50	1.5945		6.35	TAP3-40.50	TAK3-40.50	TAN3-40.50
3-B	40.60	1.5984		6.35	TAP3-40.60	TAK3-40.60	TAN3-40.60
3-B	40.70	1.6024		6.35	TAP3-40.70	TAK3-40.70	TAN3-40.70
3-B	40.80	1.6063		6.35	TAP3-40.80	TAK3-40.80	TAN3-40.80
3-B	40.90	1.6102		6.35	TAP3-40.90	TAK3-40.90	TAN3-40.90

Destičky se dodávají v balení po 1 ks

Mezisérie držáků (A, B, C, D)

Jejich použití se doporučuje, pokud vrtáme karbidovými destičkami o průměru na horním konci příslušné série, nebo u aplikací náročných na tuhost systému.
POZNÁMKA: S mezisériovými držáky mohou být použity pouze specifikované destičky, se stejným nebo větším průměrem, než mají příslušné držáky.



Destička série A + Držák série A

Destička série C + Držák série A

Destička série C + Držák série C

Destička série A + Držák série C

A25: 50 - 53

A25: 48 - 49

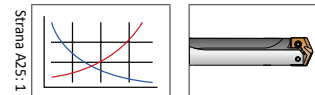

Neuvedené průměry na objednávku. Příklad objednávky:

Metrické: 13.16mm, ocel, Série 0 = Použijte obj. číslo TAP0-13.16

Palcové: 0.5180", ocel, Série 0 = Použijte obj. číslo TAP0-13.16

Karbidové břitové destičky T-A Pro

Série 3 | Rozsah průměrů: 35.05 mm - 47.80mm

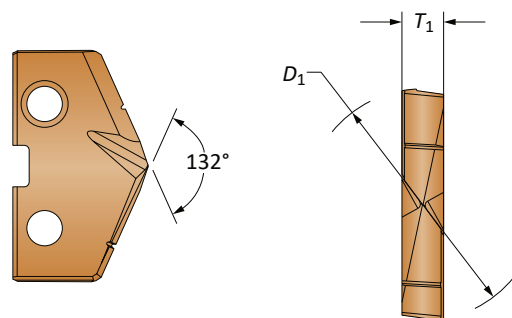

Série	Destička				Obj. číslo P	Obj. číslo K	Obj. číslo N
	D ₁ mm	D ₁ palců	Zlomkové vyjádření	T ₁ mm			
3-C	41.00	1.6142		6.35	TAP3-41.00	TAK3-41.00	TAN3-41.00
3-C	41.10	1.6181		6.35	TAP3-41.10	TAK3-41.10	TAN3-41.10
3-C	41.20	1.6220		6.35	TAP3-41.20	TAK3-41.20	TAN3-41.20
3-C	41.28	1.6252	1-5/8	6.35	TAP3-41.28	TAK3-41.28	TAN3-41.28
3-C	41.30	1.6260		6.35	TAP3-41.30	TAK3-41.30	TAN3-41.30
3-C	41.40	1.6299		6.35	TAP3-41.40	TAK3-41.40	TAN3-41.40
3-C	41.50	1.6339		6.35	TAP3-41.50	TAK3-41.50	TAN3-41.50
3-C	41.60	1.6378		6.35	TAP3-41.60	TAK3-41.60	TAN3-41.60
3-C	41.70	1.6417		6.35	TAP3-41.70	TAK3-41.70	TAN3-41.70
3-C	41.80	1.6457		6.35	TAP3-41.80	TAK3-41.80	TAN3-41.80
3-C	41.90	1.6496		6.35	TAP3-41.90	TAK3-41.90	TAN3-41.90
3-C	42.00	1.6535		6.35	TAP3-42.00	TAK3-42.00	TAN3-42.00
3-C	42.07	1.6563	1-21/32	6.35	TAP3-42.07	TAK3-42.07	TAN3-42.07
3-C	42.10	1.6575		6.35	TAP3-42.10	TAK3-42.10	TAN3-42.10
3-C	42.20	1.6614		6.35	TAP3-42.20	TAK3-42.20	TAN3-42.20
3-C	42.30	1.6654		6.35	TAP3-42.30	TAK3-42.30	TAN3-42.30
3-C	42.40	1.6693		6.35	TAP3-42.40	TAK3-42.40	TAN3-42.40
3-C	42.50	1.6732		6.35	TAP3-42.50	TAK3-42.50	TAN3-42.50
3-C	42.60	1.6772		6.35	TAP3-42.60	TAK3-42.60	TAN3-42.60
3-C	42.70	1.6811		6.35	TAP3-42.70	TAK3-42.70	TAN3-42.70
3-C	42.80	1.6850		6.35	TAP3-42.80	TAK3-42.80	TAN3-42.80
3-C	42.86	1.6874	1-11/16	6.35	TAP3-42.86	TAK3-42.86	TAN3-42.86
3-C	42.90	1.6890		6.35	TAP3-42.90	TAK3-42.90	TAN3-42.90
3-C	43.00	1.6929		6.35	TAP3-43.00	TAK3-43.00	TAN3-43.00
3-C	43.10	1.6969		6.35	TAP3-43.10	TAK3-43.10	TAN3-43.10
3-C	43.20	1.7008		6.35	TAP3-43.20	TAK3-43.20	TAN3-43.20
3-C	43.30	1.7047		6.35	TAP3-43.30	TAK3-43.30	TAN3-43.30
3-C	43.40	1.7087		6.35	TAP3-43.40	TAK3-43.40	TAN3-43.40
3-C	43.50	1.7126		6.35	TAP3-43.50	TAK3-43.50	TAN3-43.50
3-C	43.60	1.7165		6.35	TAP3-43.60	TAK3-43.60	TAN3-43.60
3-C	43.66	1.7189	1-23/32	6.35	TAP3-43.66	TAK3-43.66	TAN3-43.66
3-C	43.70	1.7205		6.35	TAP3-43.70	TAK3-43.70	TAN3-43.70
3-C	43.80	1.7244		6.35	TAP3-43.80	TAK3-43.80	TAN3-43.80
3-C	43.90	1.7283		6.35	TAP3-43.90	TAK3-43.90	TAN3-43.90
3-C	44.00	1.7323		6.35	TAP3-44.00	TAK3-44.00	TAN3-44.00
3-C	44.10	1.7362		6.35	TAP3-44.10	TAK3-44.10	TAN3-44.10
3-C	44.20	1.7402		6.35	TAP3-44.20	TAK3-44.20	TAN3-44.20
3-C	44.30	1.7441		6.35	TAP3-44.30	TAK3-44.30	TAN3-44.30

Destičky se dodávají v balení po 1 ks

Mezisérie držáků (A, B, C, D)

Jejich použití se doporučuje, pokud vrtáme karbidovými destičkami o průměru na horním konci příslušné série, nebo u aplikací náročných na tuhost systému.
POZNÁMKA: S mezisériovými držáky mohou být použity pouze specifikované destičky, se stejným nebo větším průměrem, než mají příslušné držáky.

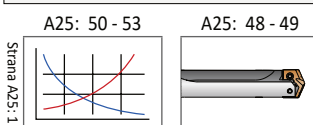
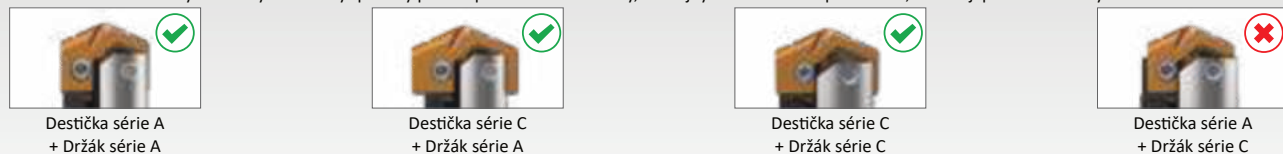

Neuvedené průměry na objednávku. Příklad objednávky:
Metrické: 13.16mm, ocel, Série 0 = Použijte obj. číslo TAP0-13.16
Palcové: 0.5180", ocel, Série 0 = Použijte obj. číslo TAP0-13.16

Karbidové břitové destičky T-A Pro

Série 3 | Rozsah průměrů: 35.05 mm - 47.80mm

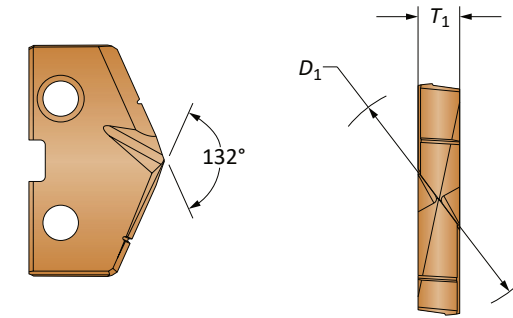

Série	Destička				Obj. číslo P	Obj. číslo K	Obj. číslo N
	D ₁ mm	D ₁ palců	Zlomkové vyjádření	T ₁ mm			
3-D	44.40	1.7480		6.35	TAP3-44.40	TAK3-44.40	TAN3-44.40
3-D	44.45	1.7500	1-3/4	6.35	TAP3-44.45	TAK3-44.45	TAN3-44.45
3-D	44.50	1.7520		6.35	TAP3-44.50	TAK3-44.50	TAN3-44.50
3-D	44.60	1.7559		6.35	TAP3-44.60	TAK3-44.60	TAN3-44.60
3-D	44.70	1.7598		6.35	TAP3-44.70	TAK3-44.70	TAN3-44.70
3-D	44.80	1.7638		6.35	TAP3-44.80	TAK3-44.80	TAN3-44.80
3-D	44.90	1.7677		6.35	TAP3-44.90	TAK3-44.90	TAN3-44.90
3-D	45.00	1.7717		6.35	TAP3-45.00	TAK3-45.00	TAN3-45.00
3-D	45.10	1.7756		6.35	TAP3-45.10	TAK3-45.10	TAN3-45.10
3-D	45.20	1.7795		6.35	TAP3-45.20	TAK3-45.20	TAN3-45.20
3-D	45.24	1.7811	1-25/32	6.35	TAP3-45.24	TAK3-45.24	TAN3-45.24
3-D	45.30	1.7835		6.35	TAP3-45.30	TAK3-45.30	TAN3-45.30
3-D	45.40	1.7874		6.35	TAP3-45.40	TAK3-45.40	TAN3-45.40
3-D	45.50	1.7913		6.35	TAP3-45.50	TAK3-45.50	TAN3-45.50
3-D	45.50	1.7913		6.35	TAP3-45.50	TAK3-45.50	TAN3-45.50
3-D	45.60	1.7953		6.35	TAP3-45.60	TAK3-45.60	TAN3-45.60
3-D	45.64	1.7969		6.35	TAP3-45.64	TAK3-45.64	TAN3-45.64
3-D	45.70	1.7992		6.35	TAP3-45.70	TAK3-45.70	TAN3-45.70
3-D	45.80	1.8031		6.35	TAP3-45.80	TAK3-45.80	TAN3-45.80
3-D	45.90	1.8071		6.35	TAP3-45.90	TAK3-45.90	TAN3-45.90
3-D	46.00	1.8110		6.35	TAP3-46.00	TAK3-46.00	TAN3-46.00
3-D	46.04	1.8126	1-13/16	6.35	TAP3-46.04	TAK3-46.04	TAN3-46.04
3-D	46.10	1.8150		6.35	TAP3-46.10	TAK3-46.10	TAN3-46.10
3-D	46.20	1.8189		6.35	TAP3-46.20	TAK3-46.20	TAN3-46.20
3-D	46.30	1.8228		6.35	TAP3-46.30	TAK3-46.30	TAN3-46.30
3-D	46.40	1.8268		6.35	TAP3-46.40	TAK3-46.40	TAN3-46.40
3-D	46.50	1.8307		6.35	TAP3-46.50	TAK3-46.50	TAN3-46.50
3-D	46.60	1.8346		6.35	TAP3-46.60	TAK3-46.60	TAN3-46.60
3-D	46.70	1.8386		6.35	TAP3-46.70	TAK3-46.70	TAN3-46.70
3-D	46.80	1.8425		6.35	TAP3-46.80	TAK3-46.80	TAN3-46.80
3-D	46.83	1.8437	1-27/32	6.35	TAP3-46.83	TAK3-46.83	TAN3-46.83
3-D	46.90	1.8465		6.35	TAP3-46.90	TAK3-46.90	TAN3-46.90
3-D	47.00	1.8504		6.35	TAP3-47.00	TAK3-47.00	TAN3-47.00
3-D	47.10	1.8543		6.35	TAP3-47.10	TAK3-47.10	TAN3-47.10
3-D	47.20	1.8583		6.35	TAP3-47.20	TAK3-47.20	TAN3-47.20
3-D	47.30	1.8622		6.35	TAP3-47.30	TAK3-47.30	TAN3-47.30
3-D	47.40	1.8661		6.35	TAP3-47.40	TAK3-47.40	TAN3-47.40
3-D	47.50	1.8661		6.35	TAP3-47.50	TAK3-47.50	TAN3-47.50
3-D	47.60	1.8740		6.35	TAP3-47.60	TAK3-47.60	TAN3-47.60
3-D	47.63	1.8752	1-7/8	6.35	TAP3-47.63	TAK3-47.63	TAN3-47.63

Destičky se dodávají v balení po 1 ks

Mezisérie držáků (A, B, C, D)

Jejich použití se doporučuje, pokud vrtáme karbidovými destičkami o průměru na horním konci příslušné série, nebo u aplikací náročných na tuhost systému.
POZNÁMKA: S mezisériovými držáky mohou být použity pouze specifikované destičky, se stejným nebo větším průměrem, než mají příslušné držáky.

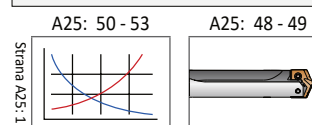
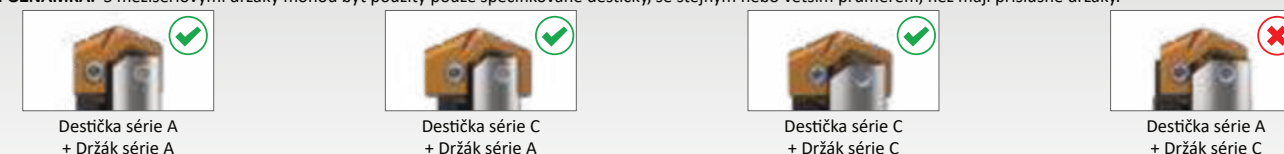

Neuvedené průměry na objednávku. Příklad objednávky:
Metrické: 13.16mm, ocel, Série 0 = Použijte obj. číslo TAP0-13.16
Palcové: 0.5180", ocel, Série 0 = Použijte obj. číslo TAP0-13.16

Břitové destičky HSS T-A Pro

Série 3 | Rozsah průměrů: 35.05 mm - 47.80mm

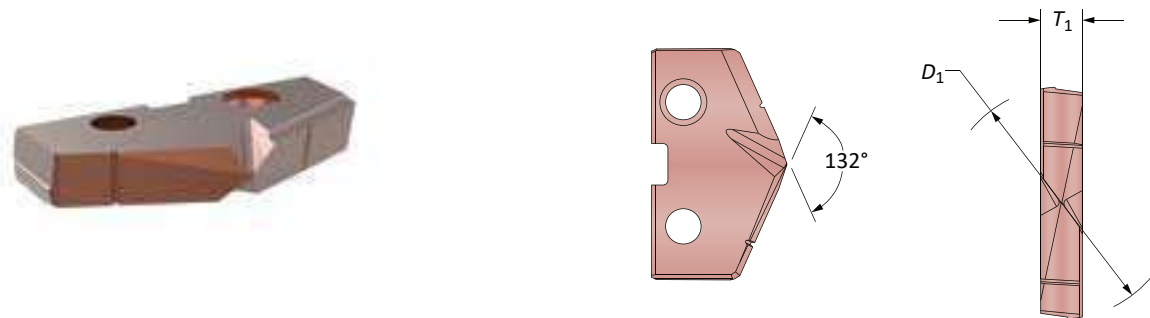

Série	Destička				Obj. číslo X
	D ₁ mm	D ₁ palců	Zlomkové vyjádření	T ₁ mm	
3-A	35.72	1.4063	1-13/32	6.35	TAX3-35.72
3-A	35.80	1.4094		6.35	TAX3-35.80
3-A	35.90	1.4134		6.35	TAX3-35.90
3-A	36.00	1.4173		6.35	TAX3-36.00
3-A	36.10	1.4213		6.35	TAX3-36.10
3-A	36.20	1.4252		6.35	TAX3-36.20
3-A	36.30	1.4291		6.35	TAX3-36.30
3-A	36.40	1.4331		6.35	TAX3-36.40
3-A	36.50	1.4370		6.35	TAX3-36.50
3-A	36.51	1.4374	1-7/16	6.35	TAX3-36.51
3-A	36.60	1.4409		6.35	TAX3-36.60
3-A	36.70	1.4449		6.35	TAX3-36.70
3-A	36.80	1.4488		6.35	TAX3-36.80
3-A	36.90	1.4528		6.35	TAX3-36.90
3-A	37.00	1.4567		6.35	TAX3-37.00
3-A	37.10	1.4606		6.35	TAX3-37.10
3-A	37.20	1.4646		6.35	TAX3-37.20
3-A	37.30	1.4685		6.35	TAX3-37.30
3-A	37.31	1.4689	1-15/32	6.35	TAX3-37.31
3-A	37.40	1.4724		6.35	TAX3-37.40
3-A	37.50	1.4764		6.35	TAX3-37.50
3-A	37.60	1.4803		6.35	TAX3-37.60
3-A	37.70	1.4843		6.35	TAX3-37.70

Destičky se dodávají v balení po 1 ks

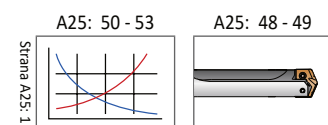

Neuvedené průměry na objednávku. Příklad objednávky:
Metrické: 13.16mm, ocel, Série 0 = Použijte obj. číslo **TAP0-13.16**
Palcové: 0.5180", ocel, Série 0 = Použijte obj. číslo **TAP0-13.16**

Břitové destičky HSS T-A Pro

Série 3 | Rozsah průměrů: 35.05 mm - 47.80mm

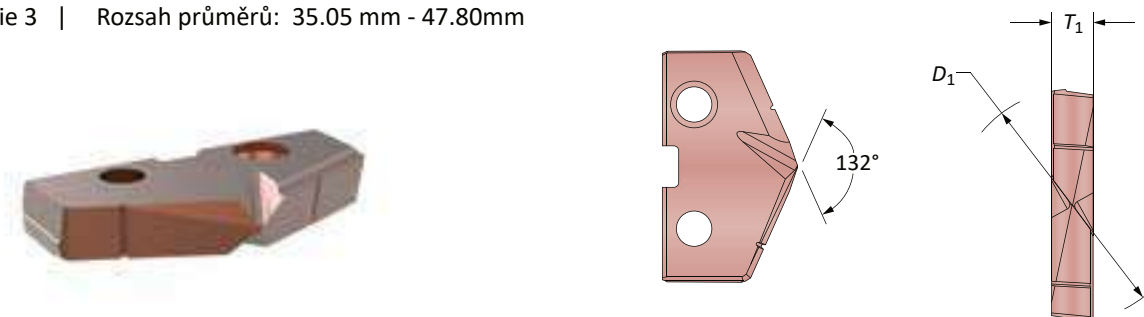

Série	Destička				Obj. číslo X
	D ₁ mm	D ₁ palců	Zlomkové vyjádření	T ₁ mm	
3-B	37.80	1.4882		6.35	TAX3-37.80
3-B	37.90	1.4921		6.35	TAX3-37.90
3-B	38.00	1.4961		6.35	TAX3-38.00
3-B	38.10	1.5000	1-1/2	6.35	TAX3-38.10
3-B	38.20	1.5039		6.35	TAX3-38.20
3-B	38.30	1.5079		6.35	TAX3-38.30
3-B	38.40	1.5118		6.35	TAX3-38.40
3-B	38.50	1.5157		6.35	TAX3-38.50
3-B	38.60	1.5197		6.35	TAX3-38.60
3-B	38.70	1.5236		6.35	TAX3-38.70
3-B	38.80	1.5276		6.35	TAX3-38.80
3-B	38.89	1.5311	1-17/32	6.35	TAX3-38.89
3-B	38.90	1.5315		6.35	TAX3-38.90
3-B	39.00	1.5354		6.35	TAX3-39.00
3-B	39.10	1.5394		6.35	TAX3-39.10
3-B	39.20	1.5433		6.35	TAX3-39.20
3-B	39.29	1.5469		6.35	TAX3-39.29
3-B	39.30	1.5472		6.35	TAX3-39.30
3-B	39.40	1.5512		6.35	TAX3-39.40
3-B	39.50	1.5551		6.35	TAX3-39.50
3-B	39.60	1.5591		6.35	TAX3-39.60
3-B	39.69	1.5626	1-9/16	6.35	TAX3-39.69
3-B	39.70	1.5630		6.35	TAX3-39.70
3-B	39.80	1.5669		6.35	TAX3-39.80
3-B	39.90	1.5709		6.35	TAX3-39.90
3-B	40.00	1.5748		6.35	TAX3-40.00
3-B	40.10	1.5787		6.35	TAX3-40.10
3-B	40.20	1.5827		6.35	TAX3-40.20
3-B	40.30	1.5866		6.35	TAX3-40.30
3-B	40.40	1.5906		6.35	TAX3-40.40
3-B	40.48	1.5937	1-19/32	6.35	TAX3-40.48
3-B	40.50	1.5945		6.35	TAX3-40.50
3-B	40.60	1.5984		6.35	TAX3-40.60
3-B	40.70	1.6024		6.35	TAX3-40.70
3-B	40.80	1.6063		6.35	TAX3-40.80
3-B	40.90	1.6102		6.35	TAX3-40.90

Destičky se dodávají v balení po 1 ks

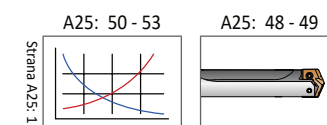

Neuvedené průměry na objednávku. Příklad objednávky:
Metrické: 13.16mm, ocel, Série 0 = Použijte obj. číslo **TAP0-13.16**
Palcové: 0.5180", ocel, Série 0 = Použijte obj. číslo **TAP0-13.16**

Břitové destičky HSS T-A Pro

Série 3 | Rozsah průměrů: 35.05 mm - 47.80 mm

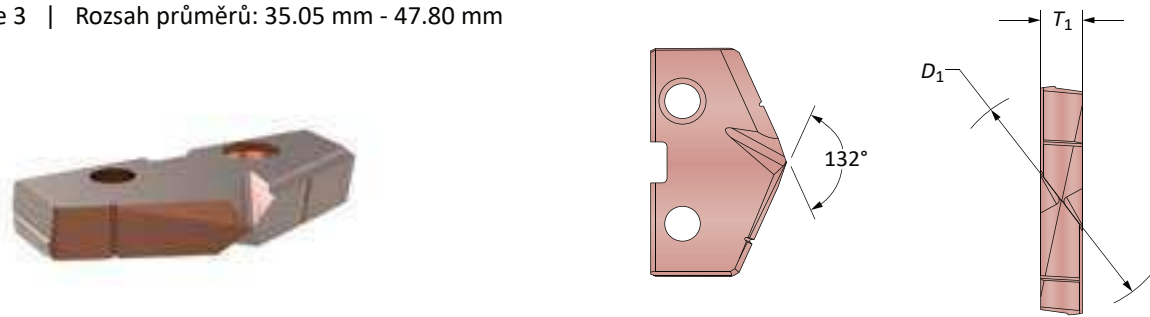

Série	Destička				Obj. číslo X
	D ₁ mm	D ₁ palců	Zlomkové vyjádření	T ₁ mm	
3-C	41.00	1.6142		6.35	TAX3-41.00
3-C	41.10	1.6181		6.35	TAX3-41.10
3-C	41.20	1.6220		6.35	TAX3-41.20
3-C	41.28	1.6252	1-5/8	6.35	TAX3-41.28
3-C	41.30	1.6260		6.35	TAX3-41.30
3-C	41.40	1.6299		6.35	TAX3-41.40
3-C	41.50	1.6339		6.35	TAX3-41.50
3-C	41.60	1.6378		6.35	TAX3-41.60
3-C	41.70	1.6417		6.35	TAX3-41.70
3-C	41.80	1.6457		6.35	TAX3-41.80
3-C	41.90	1.6496		6.35	TAX3-41.90
3-C	42.00	1.6535		6.35	TAX3-42.00
3-C	42.07	1.6563	1-21/32	6.35	TAX3-42.07
3-C	42.10	1.6575		6.35	TAX3-42.10
3-C	42.20	1.6614		6.35	TAX3-42.20
3-C	42.30	1.6654		6.35	TAX3-42.30
3-C	42.40	1.6693		6.35	TAX3-42.40
3-C	42.50	1.6732		6.35	TAX3-42.50
3-C	42.60	1.6772		6.35	TAX3-42.60
3-C	42.70	1.6811		6.35	TAX3-42.70
3-C	42.80	1.6850		6.35	TAX3-42.80
3-C	42.86	1.6874	1-11/16	6.35	TAX3-42.86
3-C	42.90	1.6890		6.35	TAX3-42.90
3-C	43.00	1.6929		6.35	TAX3-43.00
3-C	43.10	1.6969		6.35	TAX3-43.10
3-C	43.20	1.7008		6.35	TAX3-43.20
3-C	43.30	1.7047		6.35	TAX3-43.30
3-C	43.40	1.7087		6.35	TAX3-43.40
3-C	43.50	1.7126		6.35	TAX3-43.50
3-C	43.60	1.7165		6.35	TAX3-43.60
3-C	43.66	1.7189	1-23/32	6.35	TAX3-43.66
3-C	43.70	1.7205		6.35	TAX3-43.70
3-C	43.80	1.7244		6.35	TAX3-43.80
3-C	43.90	1.7283		6.35	TAX3-43.90
3-C	44.00	1.7323		6.35	TAX3-44.00
3-C	44.10	1.7362		6.35	TAX3-44.10
3-C	44.20	1.7402		6.35	TAX3-44.20
3-C	44.30	1.7441		6.35	TAX3-44.30

Destičky se dodávají v balení po 1 ks

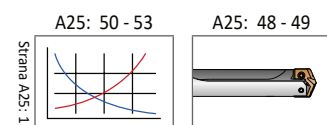

Neuvedené průměry na objednávku. Příklad objednávky:
Metrické: 13.16mm, ocel, Série 0 = Použijte obj. číslo **TAP0-13.16**
Palcové: 0.5180", ocel, Série 0 = Použijte obj. číslo **TAP0-13.16**

Břitové destičky HSS T-A Pro

Série 3 | Rozsah průměrů: 35.05 mm - 47.80 mm

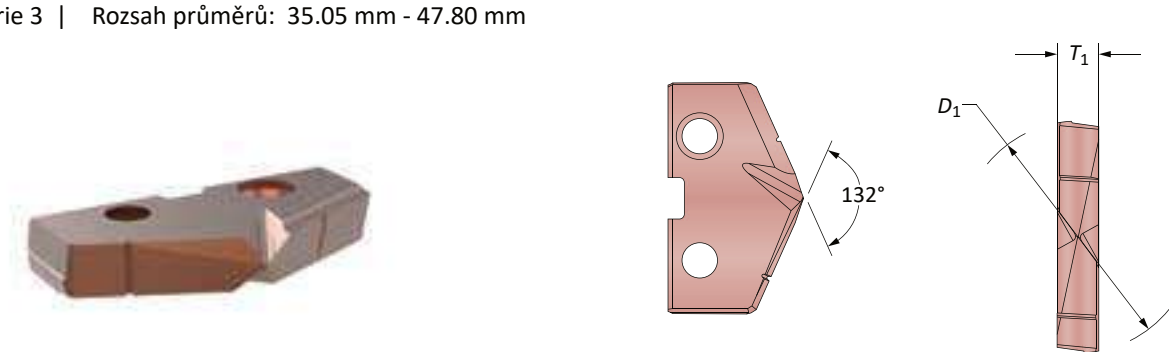

Série	Destička				Obj. číslo X
	D ₁ mm	D ₁ palců	Zlomkové vyjádření	T ₁ mm	
3-D	44.40	1.7480		6.35	TAX3-44.40
3-D	44.45	1.7500	1-3/4	6.35	TAX3-44.45
3-D	44.50	1.7520		6.35	TAX3-44.50
3-D	44.60	1.7559		6.35	TAX3-44.60
3-D	44.70	1.7598		6.35	TAX3-44.70
3-D	44.80	1.7638		6.35	TAX3-44.80
3-D	44.90	1.7677		6.35	TAX3-44.90
3-D	45.00	1.7717		6.35	TAX3-45.00
3-D	45.10	1.7756		6.35	TAX3-45.10
3-D	45.20	1.7795		6.35	TAX3-45.20
3-D	45.24	1.7811	1-25/32	6.35	TAX3-45.24
3-D	45.30	1.7835		6.35	TAX3-45.30
3-D	45.40	1.7874		6.35	TAX3-45.40
3-D	45.50	1.7913		6.35	TAX3-45.50
3-D	45.60	1.7953		6.35	TAX3-45.60
3-D	45.64	1.7969		6.35	TAX3-45.64
3-D	45.70	1.7992		6.35	TAX3-45.70
3-D	45.80	1.8031		6.35	TAX3-45.80
3-D	45.90	1.8071		6.35	TAX3-45.90
3-D	46.00	1.8110		6.35	TAX3-46.00
3-D	46.04	1.8126	1-13/16	6.35	TAX3-46.04
3-D	46.10	1.8150		6.35	TAX3-46.10
3-D	46.20	1.8189		6.35	TAX3-46.20
3-D	46.30	1.8228		6.35	TAX3-46.30
3-D	46.40	1.8268		6.35	TAX3-46.40
3-D	46.50	1.8307		6.35	TAX3-46.50
3-D	46.60	1.8346		6.35	TAX3-46.60
3-D	46.70	1.8386		6.35	TAX3-46.70
3-D	46.80	1.8425		6.35	TAX3-46.80
3-D	46.83	1.8437	1-27/32	6.35	TAX3-46.83
3-D	46.90	1.8465		6.35	TAX3-46.90
3-D	47.00	1.8504		6.35	TAX3-47.00
3-D	47.10	1.8543		6.35	TAX3-47.10
3-D	47.20	1.8583		6.35	TAX3-47.20
3-D	47.30	1.8622		6.35	TAX3-47.30
3-D	47.40	1.8661		6.35	TAX3-47.40
3-D	47.50	1.8661		6.35	TAX3-47.50
3-D	47.60	1.8740		6.35	TAX3-47.60
3-D	47.63	1.8752	1-7/8	6.35	TAX3-47.63

Destičky se dodávají v balení po 1 ks

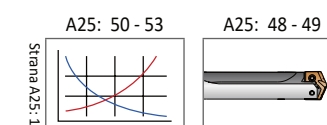

Neuvedené průměry na objednávku. Příklad objednávky:
Metrické: 13.16 mm, ocel, Série 0 = Použijte obj. číslo **TAP0-13.16**
Palcové: 0.5180", ocel, Série 0 = Použijte obj. číslo **TAP0-13.16**

Držáky T-A Pro

Série 3 Metrické | Rozsah průměrů: 35.05 mm - 47.80mm

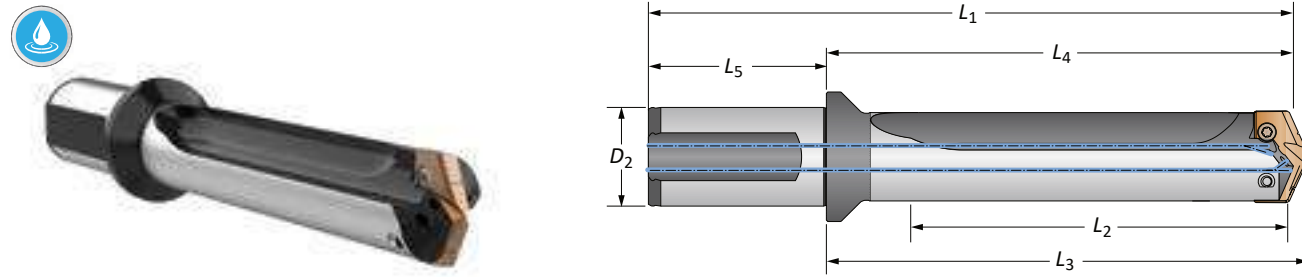

Délka	Mezisérie	Rozsah průměrů série	Tělo držáku				Stopka				Obj. číslo
			L ₂ mm	L ₄ mm	L ₃ mm	L ₁ mm	L ₅ mm	D ₂ mm	Ploška		
KRÁTKÝ	A	35.72 - 37.70	41.1	92.3	97.1	160.6	68.3	40	Ano	HTA3A01-40FM	
KRÁTKÝ	A	35.72 - 37.70	41.1	92.3	97.1	160.6	68.3	40	Ne	HTA3A01-40CM	
KRÁTKÝ	B	37.80 - 40.90	41.1	92.3	97.1	160.6	68.3	40	Ano	HTA3B01-40FM	
KRÁTKÝ	B	37.80 - 40.90	41.1	92.3	97.1	160.6	68.3	40	Ne	HTA3B01-40CM	
KRÁTKÝ	C	41.00 - 44.30	41.1	92.3	97.1	160.6	68.3	40	Ano	HTA3C01-40FM	
KRÁTKÝ	C	41.00 - 44.30	41.1	92.3	97.1	160.6	68.3	40	Ne	HTA3C01-40CM	
KRÁTKÝ	D	44.40 - 47.63	41.1	92.3	97.1	160.6	68.3	40	Ano	HTA3D01-40FM	
KRÁTKÝ	D	44.40 - 47.63	41.1	92.3	97.1	160.6	68.3	40	Ne	HTA3D01-40CM	
3xD	A	35.72 - 37.70	123.3	180.1	184.8	248.3	68.3	40	Ano	HTA3A03-40FM	
3xD	A	35.72 - 37.70	123.3	180.1	184.8	248.3	68.3	40	Ne	HTA3A03-40CM	
3xD	B	37.80 - 40.90	123.3	180.1	184.8	248.3	68.3	40	Ano	HTA3B03-40FM	
3xD	B	37.80 - 40.90	123.3	180.1	184.8	248.3	68.3	40	Ne	HTA3B03-40CM	
3xD	C	41.00 - 44.30	123.3	180.1	184.8	248.3	68.3	40	Ano	HTA3C03-40FM	
3xD	C	41.00 - 44.30	123.3	180.1	184.8	248.3	68.3	40	Ne	HTA3C03-40CM	
3xD	D	44.40 - 47.63	123.3	180.1	184.8	248.3	68.3	40	Ano	HTA3D03-40FM	
3xD	D	44.40 - 47.63	123.3	180.1	184.8	248.3	68.3	40	Ne	HTA3D03-40CM	
5xD	A	35.72 - 37.70	205.5	262.2	267.0	330.5	68.3	40	Ano	HTA3A05-40FM	
5xD	A	35.72 - 37.70	205.5	262.2	267.0	330.5	68.3	40	Ne	HTA3A05-40CM	
5xD	B	37.80 - 40.90	205.5	262.2	267.0	330.5	68.3	40	Ano	HTA3B05-40FM	
5xD	B	37.80 - 40.90	205.5	262.2	267.0	330.5	68.3	40	Ne	HTA3B05-40CM	
5xD	C	41.00 - 44.30	205.5	262.2	267.0	330.5	68.3	40	Ano	HTA3C05-40FM	
5xD	C	41.00 - 44.30	205.5	262.2	267.0	330.5	68.3	40	Ne	HTA3C05-40CM	
5xD	D	44.40 - 47.63	205.5	262.2	267.0	330.5	68.3	40	Ano	HTA3D05-40FM	
5xD	D	44.40 - 47.63	205.5	262.2	267.0	330.5	68.3	40	Ne	HTA3D05-40CM	
7xD	A	35.72 - 37.70	287.7	344.4	349.2	412.7	68.3	40	Ano	HTA3A07-40FM	
7xD	A	35.72 - 37.70	287.7	344.4	349.2	412.7	68.3	40	Ne	HTA3A07-40CM	
7xD	B	37.80 - 40.90	287.7	344.4	349.2	412.7	68.3	40	Ano	HTA3B07-40FM	
7xD	B	37.80 - 40.90	287.7	344.4	349.2	412.7	68.3	40	Ne	HTA3B07-40CM	
7xD	C	41.00 - 44.30	287.7	344.4	349.2	412.7	68.3	40	Ano	HTA3C07-40FM	
7xD	C	41.00 - 44.30	287.7	344.4	349.2	412.7	68.3	40	Ne	HTA3C07-40CM	
7xD	D	44.40 - 47.63	287.7	344.4	349.2	412.7	68.3	40	Ano	HTA3D07-40FM	
7xD	D	44.40 - 47.63	287.7	344.4	349.2	412.7	68.3	40	Ne	HTA3D07-40CM	

Příslušenství

			Přípustný uťahovací moment*
Šrouby destiček	Šrouby destiček s nylonem	Šroubovák pro destičky	1370 N-cm (121.3 in-lbs)
7514-IP20-1	7514N-IP20-1	8IP-20	

VAROVÁNÍ Doporučené hodnoty rychlostí a posuvů najdete v příslušných grafech. Pokyny pro hluboké vrtání najdete v této části katalogu na stránce A25:54. Aktuální informace a postupy najdete na www.alliedmachine.com/DeepHoleGuidelines. Technická podpora pro vaše konkrétní konkrétní aplikace je k dispozici prostřednictvím našich aplikačních techniků.



Ⓜ = Metrické (mm)
 Ⓟ = Palcové (in)
 Šrouby se dodávají v balení po 10 ks.

Držáky T-A Pro

Série 3 Metrické | Rozsah průměrů: 35.05 mm - 47.80mm

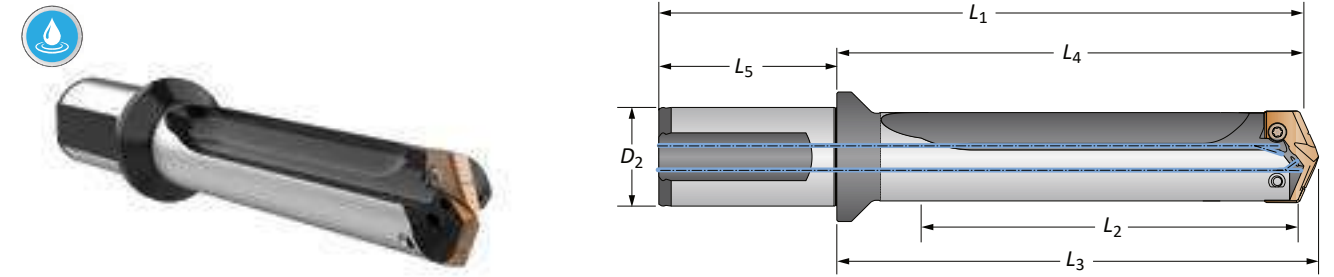

Délka	Mezisérie	Rozsah průměrů série	Tělo držáku				Stopka				Obj. číslo
			L ₂ mm	L ₄ mm	L ₃ mm	L ₁ mm	L ₅ mm	D ₂ mm	Ploška		
10xD	A	35.72 - 37.70	411.0	467.7	472.5	536.0	68.3	40	Ano	HTA3A10-40FM	
10xD	A	35.72 - 37.70	411.0	467.7	472.5	536.0	68.3	40	Ne	HTA3A10-40CM	
10xD	B	37.80 - 40.90	411.0	467.7	472.5	536.0	68.3	40	Ano	HTA3B10-40FM	
10xD	B	37.80 - 40.90	411.0	467.7	472.5	536.0	68.3	40	Ne	HTA3B10-40CM	
10xD	C	41.00 - 44.30	411.0	467.7	472.5	536.0	68.3	40	Ano	HTA3C10-40FM	
10xD	C	41.00 - 44.30	411.0	467.7	472.5	536.0	68.3	40	Ne	HTA3C10-40CM	
10xD	D	44.40 - 47.63	411.0	467.7	472.5	536.0	68.3	40	Ano	HTA3D10-40FM	
10xD	D	44.40 - 47.63	411.0	467.7	472.5	536.0	68.3	40	Ne	HTA3D10-40CM	
12xD	A	35.72 - 37.70	493.2	549.9	554.7	618.2	68.3	40	Ano	HTA3A12-40FM	
12xD	A	35.72 - 37.70	493.2	549.9	554.7	618.2	68.3	40	Ne	HTA3A12-40CM	
12xD	B	37.80 - 40.90	493.2	549.9	554.7	618.2	68.3	40	Ano	HTA3B12-40FM	
12xD	B	37.80 - 40.90	493.2	549.9	554.7	618.2	68.3	40	Ne	HTA3B12-40CM	
12xD	C	41.00 - 44.30	493.2	549.9	554.7	618.2	68.3	40	Ano	HTA3C12-40FM	
12xD	C	41.00 - 44.30	493.2	549.9	554.7	618.2	68.3	40	Ne	HTA3C12-40CM	
12xD	D	44.40 - 47.63	493.2	549.9	554.7	618.2	68.3	40	Ano	HTA3D12-40FM	
12xD	D	44.40 - 47.63	493.2	549.9	554.7	618.2	68.3	40	Ne	HTA3D12-40CM	
15xD	A	35.72 - 37.70	616.5	673.2	678.0	741.5	68.3	40	Ano	HTA3A15-40FM	
15xD	A	35.72 - 37.70	616.5	673.2	678.0	741.5	68.3	40	Ne	HTA3A15-40CM	
15xD	B	37.80 - 40.90	616.5	673.2	678.0	741.5	68.3	40	Ano	HTA3B15-40FM	
15xD	B	37.80 - 40.90	616.5	673.2	678.0	741.5	68.3	40	Ne	HTA3B15-40CM	
15xD	C	41.00 - 44.30	616.5	673.2	678.0	741.5	68.3	40	Ano	HTA3C15-40FM	
15xD	C	41.00 - 44.30	616.5	673.2	678.0	741.5	68.3	40	Ne	HTA3C15-40CM	
15xD	D	44.40 - 47.63	616.5	673.2	678.0	741.5	68.3	40	Ano	HTA3D15-40FM	
15xD	D	44.40 - 47.63	616.5	673.2	678.0	741.5	68.3	40	Ne	HTA3D15-40CM	

Příslušenství

			Přípustný uťahovací moment*
Šrouby destiček	Šrouby destiček s nylonem	Šroubovák pro destičky	1370 N-cm (121.3 in-lbs)
7514-IP20-1	7514N-IP20-1	8IP-20	

VAROVÁNÍ Doporučené hodnoty rychlostí a posuvů najdete v příslušných grafech. Pokyny pro hluboké vrtání najdete v této části katalogu na stránce A25:54. Aktuální informace a postupy najdete na www.alliedmachine.com/DeepHoleGuidelines. Technická podpora pro vaše konkrétní konkrétní aplikace je k dispozici prostřednictvím našich aplikačních techniků.



Ⓜ = Metrické (mm)
 Ⓟ = Palcové (in)
 Šrouby se dodávají v balení po 10 ks.